

# Dwyer®

**Manufacturing Excellence Since 1931**

pressure • temperature • test & data • air quality

flow • level • process control • valves



# 2021

---

[dwyer-inst.com](http://dwyer-inst.com)

## KEY MARKETS

---



### HVAC

- Building Automation
- Test Equipment
- Critical Environments
- Original Equipment  
(Chillers, Boilers, Air Handlers, Cooling Towers)
- Valve Automation

### PROCESS AUTOMATION

- Water and Wastewater
- Pharmaceutical
- Agriculture and Livestock
- Powder and Bulk
- Industrial Process
- Mining and Heavy Earth Moving
- Oil, Gas and Petrochemical
- Power
- Valve Automation

## INNOVATION AWARDS

---



Wireless Hydronic Balancing Kit  
Series 490W

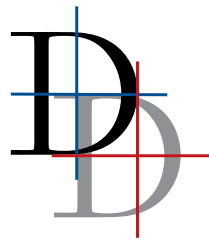

*The ACHR News* is the leading trade magazine in the heating, ventilating, air conditioning, and refrigeration industries.

### GOLD

- HVAC Mobile Meter® Software Test Instrument App
- PredictAir™ Application Software
- Air Velocity Transmitter | [Series AVUL](#)

### SILVER

- Universal Handheld Test Instrument | [Model UHH2](#)
- Wireless Hydronic Balancing Kit | [Series 490W](#)
- Hydronic Application Software

### BRONZE

- SMART Air Hood® Balancing Instrument | [Series SAH](#)
- Hydronic Differential Pressure Manometer | [Series 490A](#)
- Insertion Electromagnetic Flow Transmitter | [Series IEF](#)

# HVAC TESTING

Series 160F Pitot Tube

Model TAC-L Portable Digital Tachometer

Series 477AV Handheld Digital Manometer

Series 471B Thermo-Anemometer

Series WNT Multi-Jet NSF Certified Water Meter

Series WMH Multi-Jet Hot Water Meter

Series TUF Ultrasonic Energy Meter

Series IEFB Insertion Thermal Energy Meter

# BUILDING BALANCING

Series 160G & DP3 Air Flow Grid & Differential Pressure Module

Series SAH SMART Air Hood® Balancing Instrument & Application Software

Mobile Meter® HVAC Software App

Series 160F Pitot Tube

Series PUB Portable Ultrasonic Flowmeter Kit

Model TAC-L Portable Digital Tachometer

Series 490W Hydronic Differential Pressure Manometer

Series 477AV Digital Manometer

Series 478A Digital Manometer

## AIR HANDLER

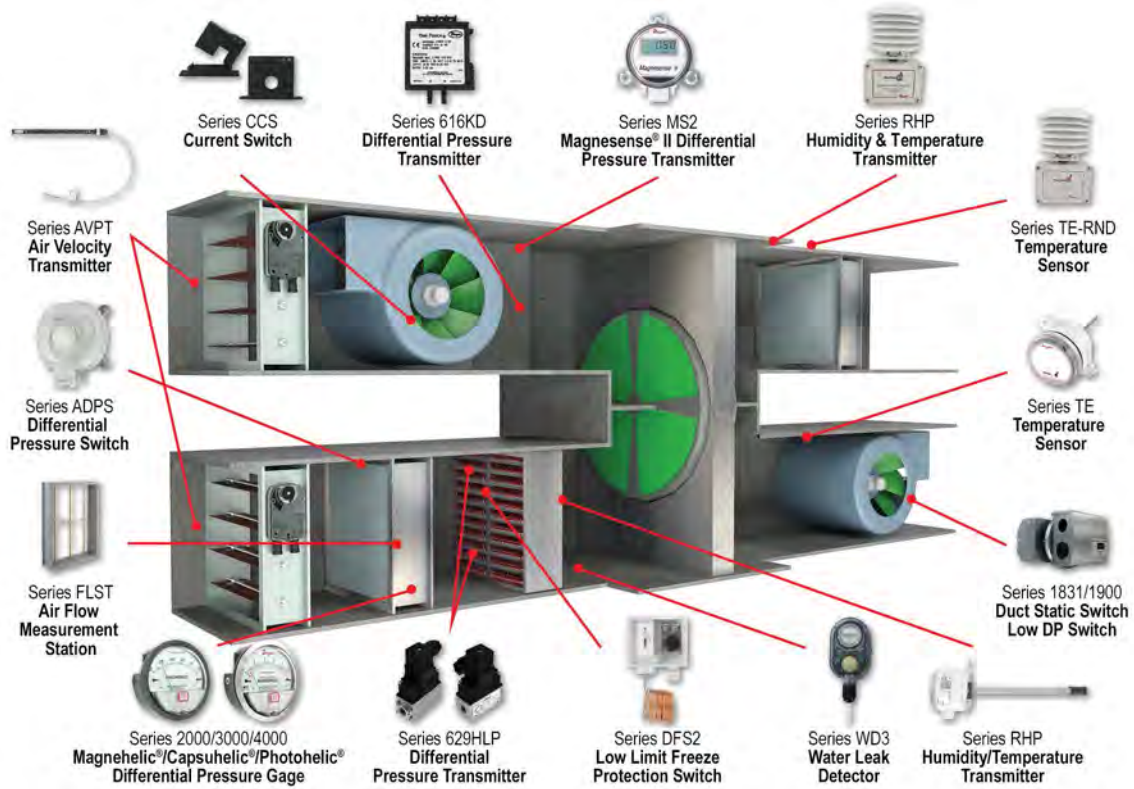

## TERMINAL UNIT

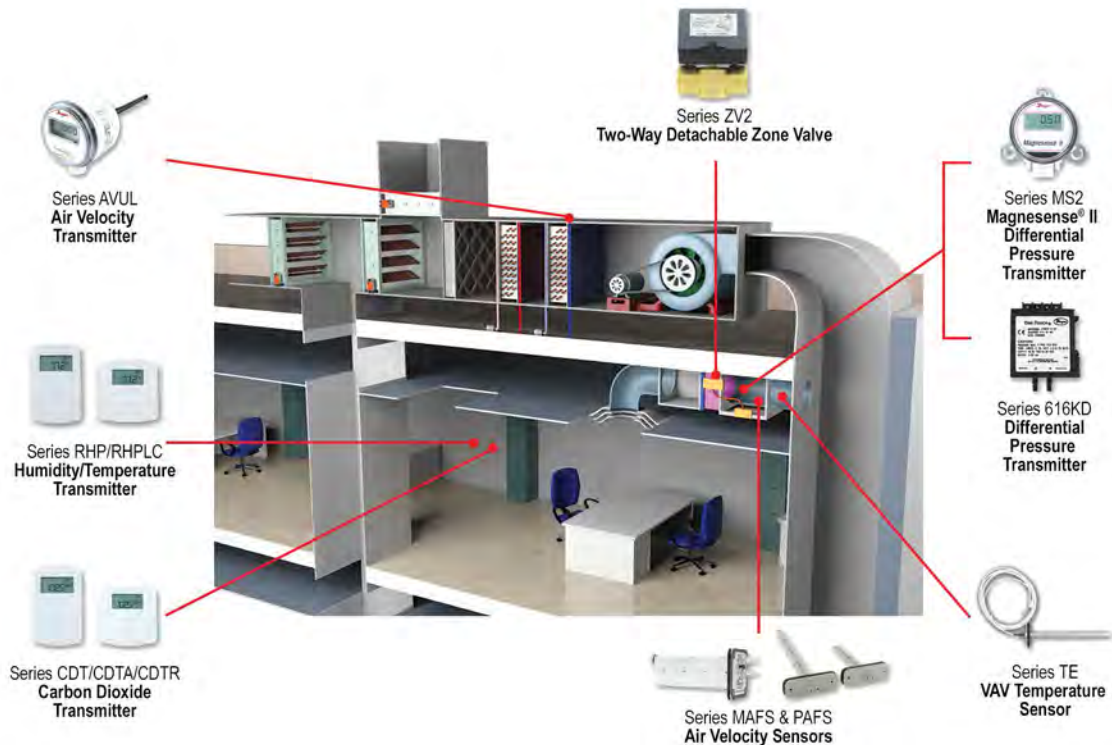

# CHILLER PLANT

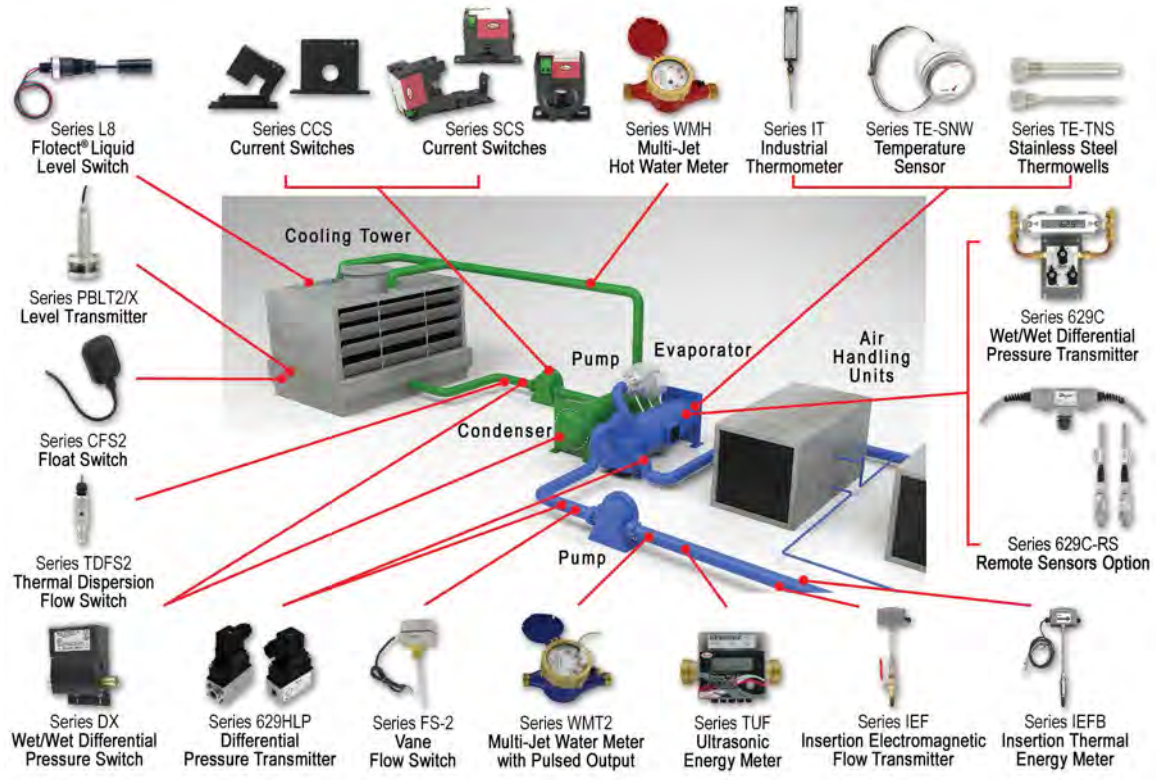

# ISOLATION ROOM

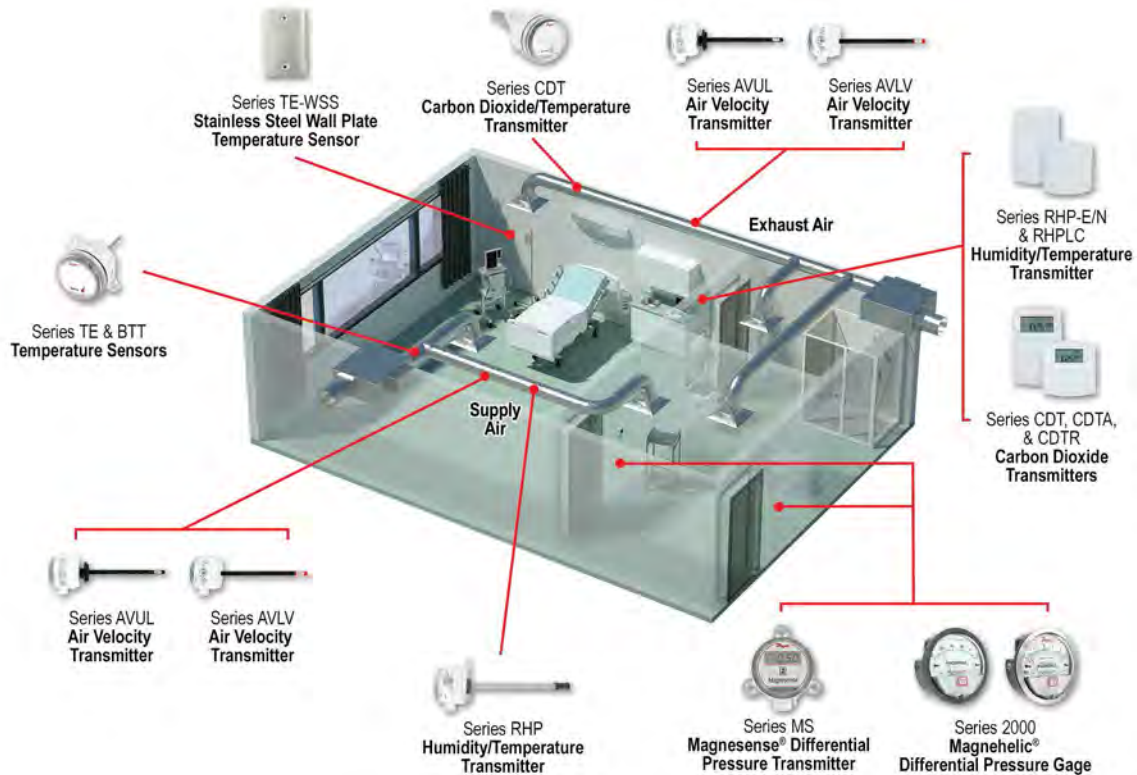

## CONTAINMENT CHAMBER/BOX

Series AVUL Air Velocity Transmitter

Series RHP Humidity/Temperature Transmitter

Series SPPM Smart Programmable Panel Meter

Series SPPM2 Graphical User Interface Panel Meter

Series THC Temperature/Humidity Switch

Series 2000 Magnehelic® Differential Pressure Gage

Series DM-2000 Differential Pressure Transmitter

Series 616WL Differential Pressure Transmitter

Series DH3 Differential Pressure Controller

Series VF Visi-Float® Flowmeter

## CLEAN ROOM

Series ADPS Differential Pressure Switch

Series RHP-M Humidity/Temperature Transmitter

Series AVLV Air Velocity Transmitter

Series 641 Air Velocity Transmitter

Series 605 Magnehelic® Differential Pressure Indicating Transmitter

Series SPPM2 Graphical User Interface Panel Meter

Series RSM Room Status Monitor

Model 670 Fume Hood Monitor

Series TE-E/N Wall Mount Temperature Sensor

Series TE-WSS Stainless Steel Wall Plate Temperature Sensor

Series 4B-33-986/U Temperature/Process Controller

Series 2000 Magnehelic® Differential Pressure Gage

# MIDSTREAM REFINERY/CHEM PLANT

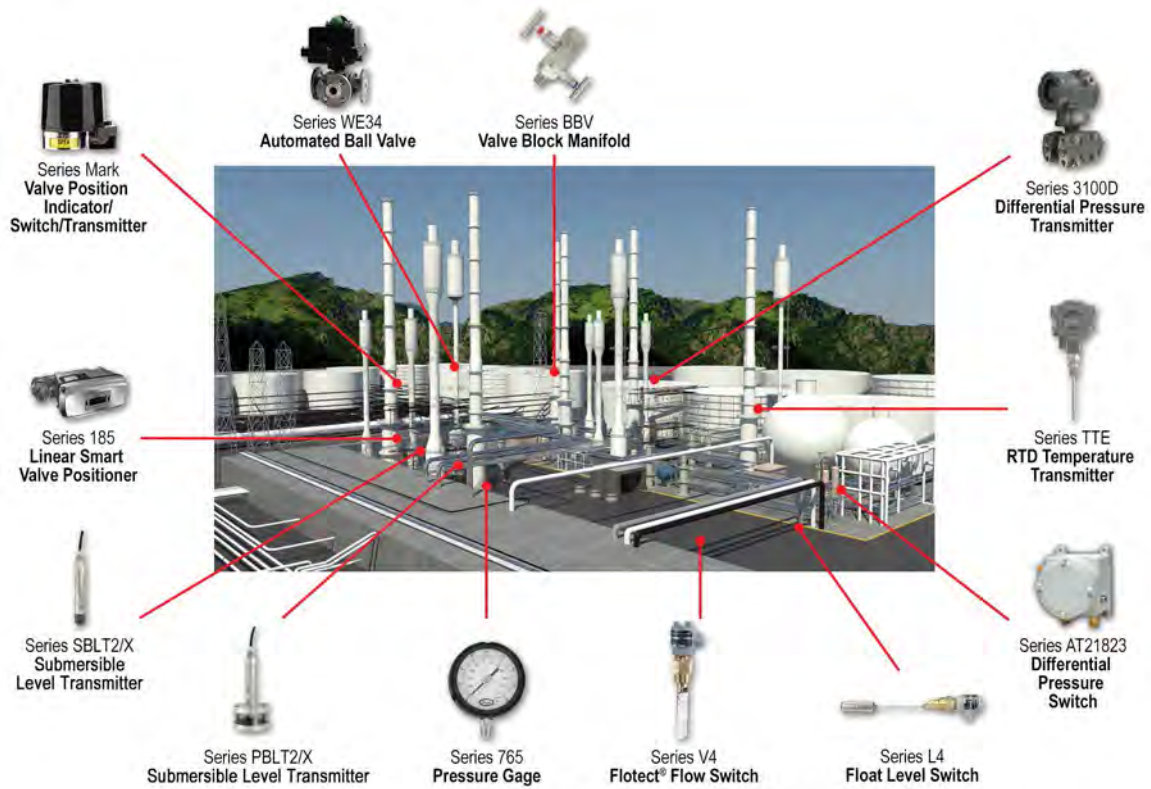

# DUST COLLECTOR

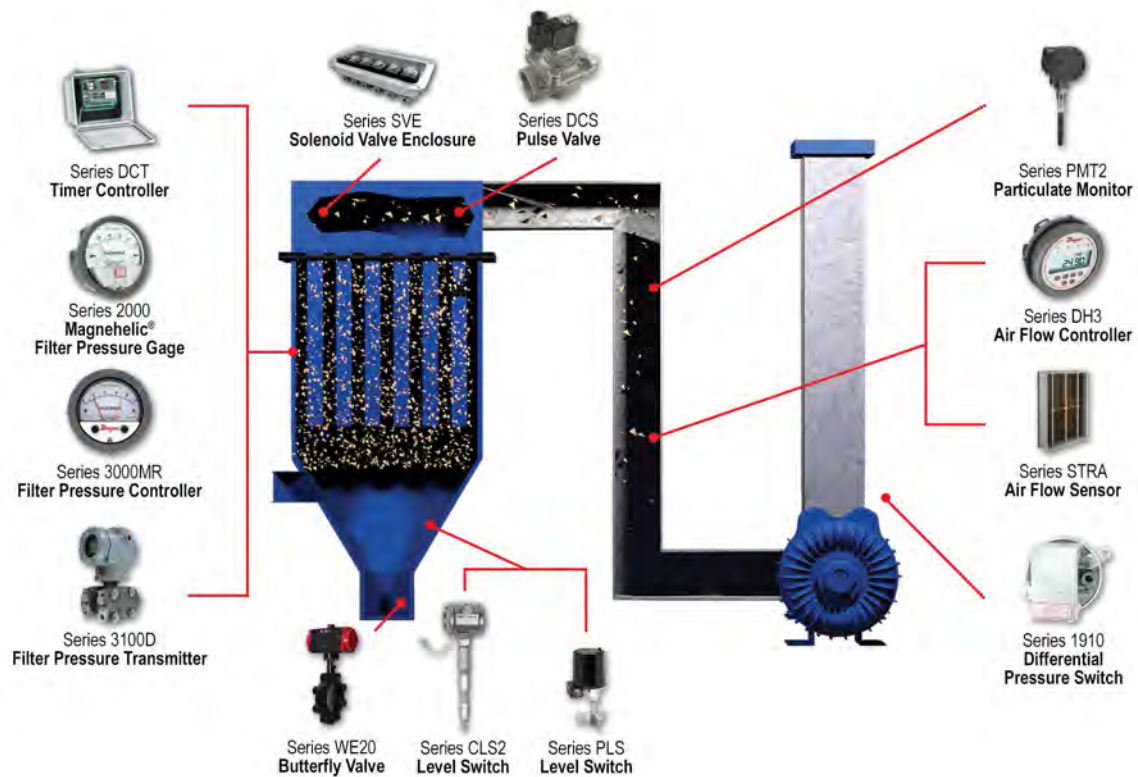

## PUMP SKID

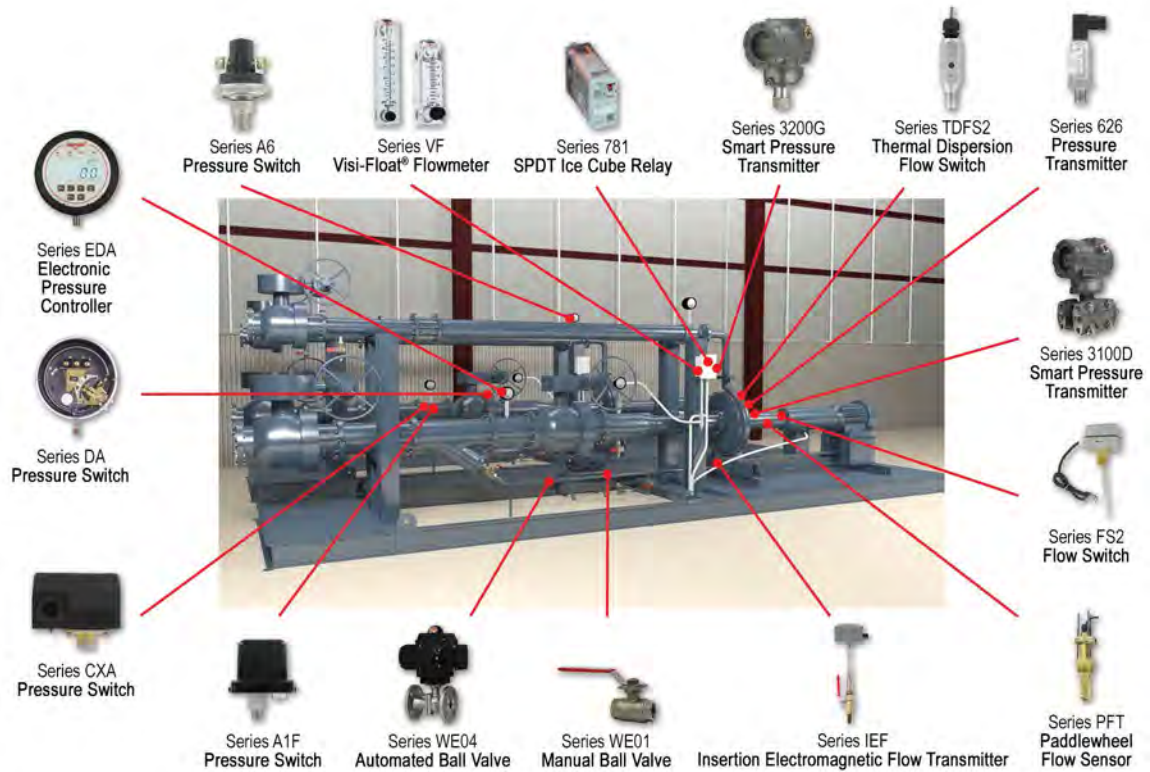

## CLEAN WATER

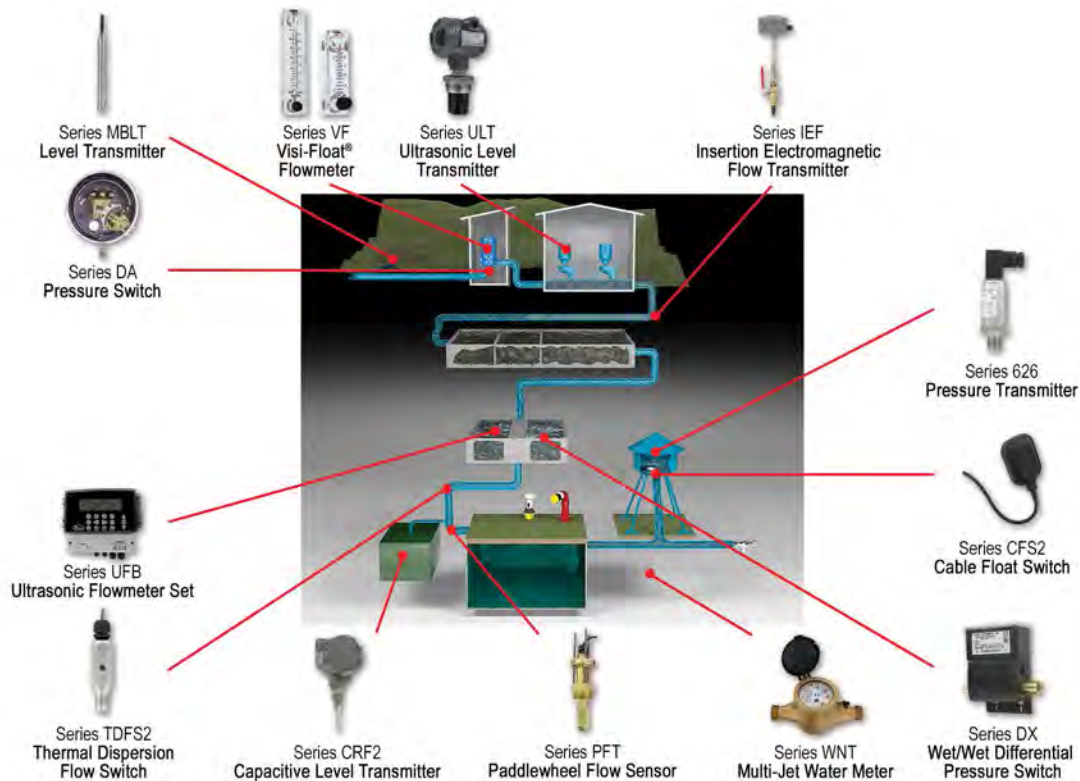



# WASTEWATER

Series DA & EDA Pressure Switch & Controller

Series L4 Float Level Switch

Series L6 Float Level Switch

Series TTE Temperature Transmitter

Series VF Visi-Float® Flowmeter

Series WE Control Valve

Series 2000 Magnehelic® Differential Pressure Gage

Series DX Pressure Switch

Series UFB Ultrasonic Flowmeter Set

Series 3100D & 3200G Process Pressure Transmitters

Series IEF Insertion Electromagnetic Flow Transmitter

Series ULT Ultrasonic Level Transmitter

Series PUB Portable Ultrasonic Flowmeter Kit

Series 626/628 Pump Transmitter

Series FBLT Level Transmitter

Series PBLT2/X Level Transmitter

# IRRIGATION

Series DX Differential Pressure Switch

Series 626/628 Pressure Transmitter

Series PFT Paddlewheel Flow Sensor

Series TDFS2 Thermal Dispersion Flow Switch

Series WE31 Automated Ball Valve

Series WE01 Manual Ball Valve

Series WMT2 Water Meter

Series WPT Multi-Jet Water Meter

Series SBSV-B Solenoid Valve

Series PDWS Flow Sensor

Series WM2 Water Meter

Series MBLT Level Transmitter

Series V10 Flow Switch

PRODUCT APPLICATIONS

# POULTRY/HOG/GREENHOUSES

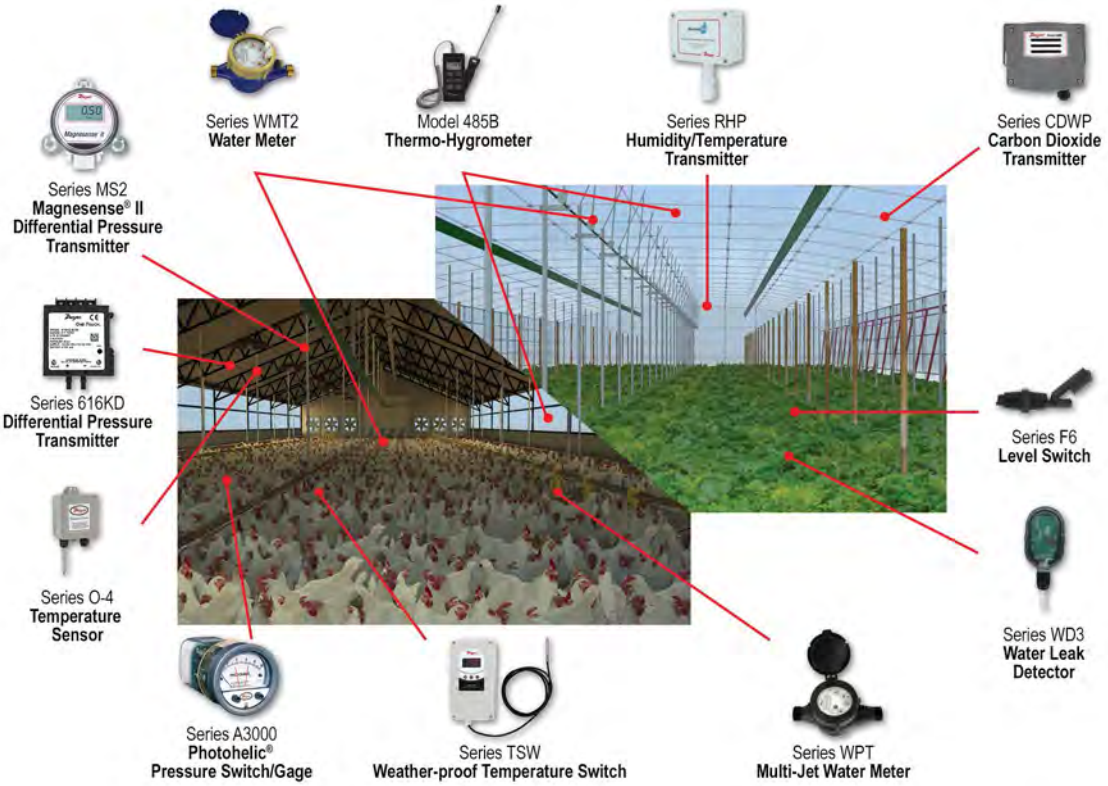

# RECENT INNOVATIONS

---



## TEST, ADJUST, AND BALANCE KIT SERIES TABKIT

- Everything a balancing technician needs in a single case
- Durability, repeatability, and reliability in every instrument
- Save time by sending everything back to us, we can recalibrate all equipment in the kit

PAGE 163

---



## THERMO-HYGROMETER PROBE, THERMO-ANEMOMETER PROBE & 100 MM VANE THERMO-ANEMOMETER PROBE SERIES RP3/AP3/VP3

- New Bluetooth wireless probes
- Wirelessly connect directly to your mobile device
- Used in conjunction with the Dwyer® Mobile Meter® app

PAGE 164

---



## WIRELESS DIFFERENTIAL PRESSURE MODULE SERIES DP3

- Auto-ranging differential pressure module
- Highly accurate and ideal for low flow applications
- Used in conjunction with the Dwyer® Mobile Meter® app

PAGE 165

---



## PENCIL STYLE AIR VELOCITY TRANSMITTER SERIES AVPT

- Air velocity ranges from 1000 to 4000 FPM (5 to 20 m/s)
- Insertion lengths of 6 or 12 inches
- Low temperature functionality for outdoor air flow measurement

PAGE 216

---



## AIR VELOCITY TRANSMITTER SERIES AVLV

- Air velocity ranges from 100 to 400 FPM (0.5 to 2 m/s)
- High accuracy 1 or 2% air velocity measurement device for critical environments
- Analog or BACnet/Modbus® communications simplify device setup

PAGE 217

---

Modbus® is a registered trademark of Schneider Automation, Inc.

# RECENT INNOVATIONS

---



## CARBON DIOXIDE TRANSMITTER SERIES CDWP

- Single beam dual wavelength NDIR CO<sub>2</sub> sensor automatically corrects for aging effects
- Durable and rugged aluminum housing designed to withstand 168 hour salt spray test
- Ranges include 2,000, 5,000, and 10,000 PPM allowing for use in animal husbandry as well as mechanical rooms utilizing CO<sub>2</sub> based refrigerants

PAGE 226

---



## CARBON MONOXIDE TRANSMITTER AND SWITCH SERIES CMS300

- Field selectable current or voltage analog outputs
- Integral SPDT relay contact for low or high alarm
- Jumper selectable alarm set points of 25, 60, or 150 PPM

PAGE 232

---



## INSERTION ELECTROMAGNETIC FLOW TRANSMITTER SERIES IEF

- Field configurable
- Integral or remote displays allow for ultimate flexibility
- Multiple display configurations with a single unit



PAGE 292

---



## ULTRASONIC ENERGY METERS SERIES TUF

- Manufactured to comply with EN1434-1 requirements
- Compact energy monitoring
- BACnet or Modbus<sup>®</sup> communication outputs

PAGE 293

---



## INSERTION THERMAL ENERGY METER SERIES IEFB

- Field configurable
- Integral or remote display for ultimate flexibility
- Complies with high accuracy requirements of EN 1434-1, ASTM E3137, CSA C900.1-13 for accurate heat measurement

PAGES 294-295

---

**PRESSURE** 1-108

- 1 Table of Contents
- 2-15 Selection Guides
- 16-17 Typical Applications
- 18-19 Pressure Sensor Accuracy
- 20-108 Product Pages

**PROCESS CONTROL** 341-376

- 341 Table of Contents
- 342-345 Selection Guides
- 346-347 Typical Applications
- 348-376 Product Pages

**TEMPERATURE** 109-148

- 109 Table of Contents
- 110-111 Selection Guides
- 112-113 Typical Applications
- 114-148 Product Pages

**VALVES** 377-446

- 377 Table of Contents
- 378-381 Selection Guides
- 382 Typical Applications
- 383 Technical Information
- 384-446 Product Pages

**TEST & DATA** 149-200

- 149 Table of Contents
- 150-153 Selection Guides
- 154-155 Typical Applications
- 156-161 HVAC Measurement Guide
- 162-200 Product Pages

**ACCESSORIES** 447-455

- 447 Table of Contents
- 448-455 Product Pages

**AIR QUALITY** 201-234

- 201 Table of Contents
- 202-203 Selection Guides
- 204-205 Typical Applications
- 206-234 Product Pages

**TECH GUIDE** 456-461

- 456-457 Glossary
- 458-460 Reference Tables
- 461 Trademark Acknowledgments

**FLOW** 235-298

- 235 Table of Contents
- 236-241 Selection Guides
- 242-244 Typical Applications
- 245 Technical Information
- 246-298 Product Pages

**INDEX** 462-476

- 462-467 Index - By Product
- 468-476 Index - By Category

**LEVEL** 299-340

- 299 Table of Contents
- 300-303 Selection Guides
- 304-305 Typical Applications
- 306-340 Product Pages

# STANDARD TERMS & CONDITIONS OF SALE

---

## DWYER INSTRUMENTS, INC. - TERMS AND CONDITIONS OF SALE - MARCH 15, 2017

1. **Prices and Specifications** are subject to change without notice.
2. **Shipping dates** are approximate. They are dependent upon credit approval and subject to delays beyond our control.
3. **Terms:** Net 30 days to companies with established credit rating. In the event Buyer fails to fulfill previous terms of payment, or in case Seller shall have any doubt at any time as to Buyer's financial responsibility, Seller may decline to make further deliveries except upon receipt of cash in advance or other special arrangements.
4. **Point and Title:** All material is sold EXW Ex Works Dwyer Instruments, Inc. Title to all material sold shall pass to buyer upon delivery by Seller to carrier at shipping point.
5. **State and Local Taxes:** Any taxes which the Seller may be required to pay or collect upon or with respect to the sale, purchase, delivery, use or consumption of any of the material covered hereby shall be for the account of the Buyer and shall be added to the purchase price.
6. **Special tooling,** dies, silk screens and molds acquired specially to produce goods for Buyer remain the property of Dwyer Instruments, Inc., and may not be removed. They will be maintained in good condition for a minimum period of three years from the date of the original purchase order.
7. **Trade Compliance:** Buyer acknowledges that the products, software, and technology, including technical information and documents (collectively "Items"), of Dwyer Instruments, Inc., are subject to regulation by agencies of the U.S. government including, but not limited to, the U.S. Department of Commerce. Buyer shall comply with the Export Administration Regulations (EAR) and all applicable U.S. laws and regulations regarding the sale, delivery and transfer of said Items. Buyer shall not, without first obtaining the required licenses, authorizations or approvals from the appropriate U.S. government agency; (i) export, re-export, transfer or divert any Item directly or indirectly to any country or national resident thereof, or any person, entity or country that has restrictions imposed upon them by the U.S. government, (ii) engage in, or knowingly sell to any party engaged in activity related to the development, production, use, testing, or maintenance of Weapons of Mass Destruction, including uses related to nuclear, missile, chemical or biological warfare, or (iii) engage in, or knowingly sell to any party engaged in activity related to the development, production, use, or maintenance of any safeguarded or unsafeguarded nuclear fuel facility or components for such facilities. Buyer shall fully cooperate with Seller, without charge, in any official audit or inspection by an authorized agent, official, employee, or accredited representative of the U.S. government. Buyer shall indemnify and hold Seller harmless from, or in connection with, any violation of this Section by Buyer, its employees, consultants, agents, or customers. The obligations, requirements and claims described herein shall survive the expiration of any business relationship with Dwyer Instruments, Inc., including its divisions, subsidiaries and affiliated companies.
8. **Distribution:** Products sold to any entity located in the U.S. must remain in the U.S. unless a Global Distribution Agreement is in force with said entity. OEM's are excluded from this requirement. Those who violate this term are subject to a reduction of discount, loss of discount, or exclusion from purchasing future products. If you want to be a Global Distributor, please contact your Global Sales Manager in your region.
9. **Limited Warranty:** The Seller warrants all Dwyer instruments and equipment to be free from defects in workmanship or material under normal use and service for a period of one year from date of shipment. Products qualifying for an extended warranty period will have the extended warranty as expressly indicated on the catalog page, web page, IOM, or will be covered by a specific written agreement that is (i) approved by an officer of Dwyer Instruments, Inc. and (ii) defines the warranty period. If no express statement of extended warranty is made, then the standard 1 year warranty applies. The Extended Limited Warranty only applies to products manufactured after April 1, 2017. The Warranty period extends from the date of shipment to the initial customer and not the project installation date or use.

Specific warranty exclusions include, but are not limited to:

- Specific product components not covered by the extended warranty:
  - o Humidity Sensors
  - o Batteries
  - o Electro-Chemical Gas Sensors
  - o Snap Switches
  - o Any component which exceed its normal life cycle
  - o Other Specific items added as required.
- Normal or excessive wear and tear is not cause for warranty replacement.
- Products not properly maintained, operated, installed, or use in an application not suited for the product.
- Modifications, alterations, changes, or additions outside those which are required for normal operation.
- Failure to notify Dwyer of any defect within a reasonable time.
- Damage which the customer has not taken timely action to minimize or mitigate.
- Products on which the labels, markings, nameplates, etc. have been tampered with.
- Products which contain broken factory seals or have been tampered with shall void warranty.

Liability under this warranty is limited to repair or replacement EXW Ex Works Dwyer Instruments, Inc. of any parts which prove to be defective within that time or repayment of the purchase price at the Seller's option. All products must be returned to the Seller, transportation prepaid, unless other arrangements have been pre-approved by Seller. All technical advice, recommendations and services are based on technical data and information which the Seller believes to be reliable and are intended for use by persons having skill and knowledge of the business, at their own discretion. In no case is Seller liable beyond replacement of equipment EXW Ex Works Dwyer Instruments, Inc. or the full purchase price. This warranty does not apply if the maximum ratings label is removed or if the instrument or equipment is abused, altered, used at ratings above the maximum specified, or otherwise misused in any way.

THIS EXPRESS LIMITED WARRANTY IS IN LIEU OF AND EXCLUDES ALL OTHER REPRESENTATIONS MADE BY ADVERTISEMENTS OR BY AGENTS AND ALL OTHER WARRANTIES, BOTH EXPRESS AND IMPLIED. THERE ARE NO IMPLIED WARRANTIES OF MERCHANTABILITY OR OF FITNESS FOR A PARTICULAR PURPOSE FOR GOODS COVERED HEREUNDER.

10. **Buyer's Remedies:** THE BUYER'S EXCLUSIVE AND SOLE REMEDY ON ACCOUNT OF OR IN RESPECT TO THE FURNISHING OF NON-CONFORMING OR DEFECTIVE MATERIAL SHALL BE TO SECURE REPLACEMENT THEREOF AS AFORESAID. THE SELLER SHALL NOT IN ANY EVENT BE LIABLE FOR THE COST OF ANY LABOR EXPENDED ON ANY SUCH MATERIAL OR FOR ANY SPECIAL, DIRECT, INDIRECT, CONSEQUENTIAL OR INCIDENTAL DAMAGES TO ANYONE BY REASON OF THE FACT THAT IT SHALL HAVE BEEN NON-CONFORMING OR DEFECTIVE.
11. **Acceptance:** All orders shall be subject to the terms and conditions contained or referred to in the Seller's quotation, acknowledgment, and to those listed here and to no others whatsoever. By placing an order you accept our terms and conditions. No waiver, alteration or modification of these terms and conditions shall be binding unless in writing and signed by an executive officer of the Seller. All orders are subject to written acceptance by Dwyer Instruments, Inc., Michigan City, Indiana, U.S.A.

**SELECTION GUIDE**  
pages 150-153

**TYPICAL APPLICATIONS**  
pages 154-155

**HVAC MEASUREMENT GUIDE**  
pages 156-161

**HVAC Balancing Instruments**  
pages 162-165

**Manometers, Portable & Air Velocity**  
pages 166-167, 171-177, 179-182

**Air Flow Grids**  
page 168

**Thermo-Hygrometers**  
page 168

**Thermo-Anemometers**  
pages 169-170

**Air Quality Meters**  
page 178

**Pressure Anemometers**  
page 178

**Pitot Tubes**  
pages 183-185

**Wind Meters**  
pages 186-187

**Vane Anemometer**  
page 187

**Flowmeter Kits**  
page 188

**Thermocouple Thermometers**  
page 188

**Gas Pressure Test Kits**  
page 189

**Tachometer**  
page 190

**Signal Generators**  
page 191

**Calibration Pumps**  
pages 192-195

**Data Loggers**  
page 196-200

**Chart Recorders**  
page 198

## FEATURED PRODUCTS

### SMART AIR HOOD® BALANCING INSTRUMENT SERIES SAH | page 162



- Patent pending Quad Flow Design Technology enables accurate readings
- Predictive Balancing that guides setting the optimal flow set point for each sequential terminal
- The ergonomic design is lighter and easier to use than traditional air flow hoods

### TEST, ADJUST, AND BALANCE KIT TABKIT | page 163



- One stop shop for air, water, temperature, humidity and electrical instruments
- A certificate of NIST calibration is included for each instrument inside the kit
- Save time by sending everything back to us, we can recalibrate all equipment in the kit

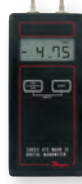



DIGITAL  
Manometers

SERIES	477AV - page 171	475 - page 172	476A - page 173	478A - page 173
Range	1 in w.c. to 150 psi (.25 kPa to 10.34 bar)	1 in w.c. to 150 psi (.25 kPa to 10.34 bar)	±20 in w.c. (±5 kPa)	±4 in w.c.; ±60 in w.c. (±1 kPa; ±15 kPa)
Service	Air and compatible gases	Air and compatible combustible gases	Air and compatible gases	Air and compatible gases
Wetted Materials	Consult factory	Consult factory	Consult factory	Consult factory
Accuracy	±0.5% FS	±0.5% FS	±1.0% FS	±0.5% FS
Pressure Limits	5 psig (1 to 10 in w.c.); 10 psig (20 to 40 in w.c.); 30 psig (200 in w.c. to 10 psi); 60 psig (20 to 30 psi); 150 psig (100 psi); 200 psig (150 psi)	5 psig (1 to 10 in w.c.); 10 psig (20 to 40 in w.c.); 30 psig (200 in w.c. to 10 psi); 60 psig (20 to 30 psi); 150 psig (100 psi); 200 psig (150 psi)	5 psig (.34 bar)	5 psig (.34 bar)
Temperature Limits	0 to 140°F (-17.8 to 60°C)	0 to 140°F (-17.8 to 60°C)	0 to 140°F (-17.8 to 60°C)	0 to 140°F (-17.8 to 60°C)
Comp. Temp. Limits	32 to 104°F (0 to 40°C)	32 to 104°F (0 to 40°C)	32 to 104°F (0 to 40°C)	32 to 104°F (0 to 40°C)
Housing Protection	Rugged aluminum housing	Rugged aluminum housing	Rugged aluminum housing	Rugged aluminum housing
Display	4-digit backlit LCD	4-digit LCD	4-digit LCD	4-digit LCD
Memory	40 readings	N/A	N/A	N/A
Process Connection	(2) Barbed connections for use with 1/8" or 3/16" ID tubing (Compression fittings for -7, -8 ranges)	(2) Barbed connections for use with 1/8" or 3/16" ID tubing (Compression fittings for -7, -8 ranges)	Barbed connection for use with 3/16" or 1/4" ID tubing	(2) Barbed connection for use with 3/16" or 1/4" ID tubing
Approvals	CE	CE, FM	CE	CE

These Selection Guides are for quick comparison of similar products. Please refer to the catalog page number referenced for complete product information and specifications.









# DIGITAL Manometers

				
<b>SERIES</b>	<b>477B</b> - page 174	<b>HM35</b> - page 176	<b>HM28</b> - page 176	<b>490A</b> - page 177
<b>Range</b>	20 in w.c. to 100 psi (4.982 to 689.5 kPa)	10 in w.c. to 1305 psi (2.5 to 9000 kPa)	10 in w.c. to 245 psi (2.5 to 1700 kPa)	15 to 200 psi (1 to 13.8 bar)
<b>Service</b>	Air and compatible gases	Air and compatible gases	Air and compatible gases	Compatible gases and liquids
<b>Wetted Materials</b>	Consult factory	18/8 SS	18/8 SS	316L SS; With 3-way valve: Buna-N, silicone grease, PTFE, brass 360, copper, reinforced acetal copolymer
<b>Accuracy</b>	±0.1% FS	(±0.2% FS, ±0.1% FS, or ±0.05% FS) ±1 digit	(±0.2% FS, ±0.1% FS, or ±0.05% FS) ±1 digit	±0.5% FS
<b>Pressure Limits</b>	3 psig (20 to 40 in w.c.); 15 psig (200 in w.c.); 30 psig (10 psi); 60 psig (30 psi); 100 psig (50 psi); 200 psig (100 psi)	N/A	N/A	30 psig (15 psi); 60 psig (30 psi); 100 psig (50 psi); 200 psig (100 psi); 400 psig (200 psi); 1000 psig (500 psi)
<b>Temperature Limits</b>	0 to 140°F (-17.8 to 60°C)	32 to 122°F (0 to 50°C)	23 to 122°F (-5 to 50°C)	32 to 140°F (0 to 60°C)
<b>Comp. Temp. Limits</b>	N/A	N/A	N/A	N/A
<b>Housing Protection</b>	Rugged aluminum housing	IP54 (NEMA 3)	IP54 (NEMA 3)	Rugged aluminum housing
<b>Display</b>	4-digit backlit LCD	Graphical backlit LCD, 128 x 64 points	2 line, 16 character, dot matrix LCD, with switchable display sizes	4-digit backlit LCD
<b>Memory</b>	40 readings	10,742 readings	10,742 readings	Up to 40 readings
<b>Process Connection</b>	(2) Barbed connections for use with 1/8" or 3/16" ID tubing (Compression fittings for -6, -7 ranges)	Hose 4/6 mm or 1/8" NPT	Hose 4/6 mm or 1/8" NPT	(2) 1/8" female NPT
<b>Approvals</b>	CE	N/A	N/A	CE

**Dwyer****THERMO**  
Anemometers

<b>SERIES</b>	<b>471B</b> - page 169	<b>473B</b> - page 170
<b>Air Velocity Range</b>	0 to 6000 FPM (0 to 30 m/s)	40 to 5000 FPM (0.2 to 25 m/s)
<b>Air Velocity Accuracy</b>	±3% FS	±1.5% of reading ±20 FPM
<b>Temperature Range</b>	-40 to 212°F (-40 to 100°C)	-20 to 212°F (-29 to 100°C)
<b>Temperature Accuracy</b>	±0.5°F (±0.28°C)	±0.54°F (±0.3°C)
<b>Humidity Range</b>	N/A	0 to 100% RH
<b>Humidity Accuracy</b>	N/A	±2% RH
<b>Air Volume Range</b>	19,999 in selected flow units	19,999 in selected flow units
<b>Wet Bulb Range</b>	N/A	N/A
<b>Meter Temperature Range</b>	Process Air Velocity: -20 to 212°F (-29 to 100°C); Process Temperature: -40 to 212°F (-40 to 100°C); Ambient: 5 to 125°F (-15 to 51°C)	Process: -20 to 212°F (-29 to 100°C); Ambient: 5 to 125°F (-15 to 51°C)
<b>Meter Humidity Limits</b>	N/A	N/A
<b>Display</b>	4.5-digit backlit LCD	4.5-digit backlit LCD
<b>Approvals</b>	CE	N/A

# CALIBRATION Pumps

							
<b>SERIES</b>	<b>HP</b> - page 192	<b>CHP</b> - page 192	<b>A-396A</b> - page 193	<b>PCHP</b> - page 194	<b>HCHP</b> - page 194	<b>LPCP</b> - page 195	<b>BCHP</b> - page 195
<b>Output Range</b>	-27" Hg to 45 psig (-0.91 to 3 bar)	-28.8" Hg to 100 psi (-0.975 to 3.4 bar)	<1 in w.c. to 72 psig (5 bar)	-28" Hg to 600 psi (-0.945 to 40 bar)	0 to 10,000 psi (0 to 700 bar)	-5.8 psi to 5.8 psi (-0.4 to 0.4 bar)	-28" Hg to 870 psi (-0.95 to 60 bar)
<b>Process Connection</b>	1/4" female NPT	1/8" female NPT	Barbed fitting or 1/8" female NPT	1/4" female NPT/BSPT	1/4" female NPT/BSPT	M20x1.5 or 1/4" female NPT	1/4" female BSPT (NPT available)
<b>Gage Connection</b>	1/4" female NPT	1/8" female NPT	N/A	1/8" female NPT/BSPT	1/4" female NPT/BSPT	M20x1.5 or 1/4" female NPT	1/2" female BSPT
<b>Materials</b>	N/A	Acetal plastic and anodized aluminum	N/A	SS fittings, anodized aluminum housing, plastic/rubber handles, and nitrile O-rings	SS, polyurethane, anodized hard-coat aluminum, PTFE, and nitrile	Ram/adapters: 316 SS, Body: Steel/aluminum; Seals: Buna-N	Anodized aluminum, brass, and ABS



**Current/voltage signal generator used to calibrate panel meters**

The Model CSG digital signal generator is perfect for generating or simulating input signals to panel meters and process controllers. The signal generator is capable of sourcing up to 10 VDC or 20 mA in 1 VDC or 1 mA steps. The backlit digital display allows users to quickly compare the reading on the Model CSG to that of the panel meter or process controller. The signal from the Model CSG can be used to set up the upper and lower limits of the process range. It can also be used to ensure that set point and alarm functions are working properly on the panel meter or process controller.

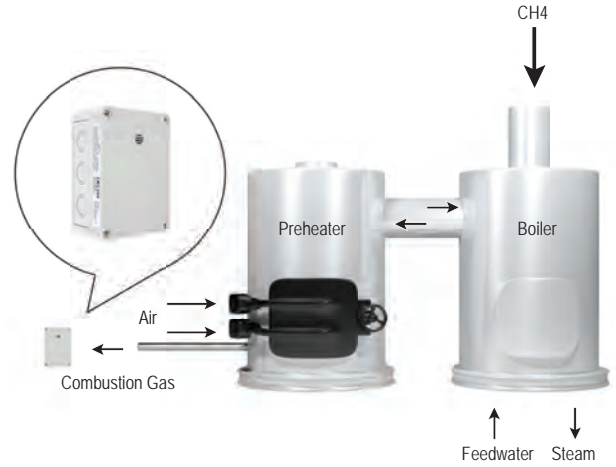

**Carbon monoxide transmitter/switch maximizes boiler efficiency while monitoring harmful products of combustion**

There are several critical factors in attaining efficient combustion for boilers and other combustors. Monitoring the temperature of combustion and minimizing the amount of excess air in the system are undoubtedly essential steps. A Dwyer® Model CMS300 measures harmful CO gas bi-products of the combustion cycle in a boiler system. The switch contact in the CMS300 can be used for a local alarm indication, in addition to sending an analog output to a building control system.

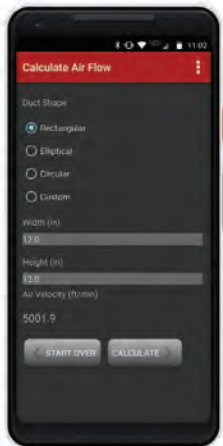

**FREE DOWNLOAD!**  
Download our Air Velocity and Flow Calculator app today.



**HVAC mobile application**

For those customers in the HVAC or BAS industry, Dwyer offers the Air Velocity and Flow Calculator App available on the Google Play® store. One can easily convert velocity pressure to air velocity or air velocity to air volume. Converting velocity pressure to air volume is advantageous for effortlessly changing the pressure on your Magnehelic® differential pressure gage or manometer to velocity. Moreover, this calculator also includes air density factors from humidity levels. By utilizing the air velocity to air volume functionality, one can simplistically convert the air velocity to air flow rates from duct dimensions, with just the tap of a button.

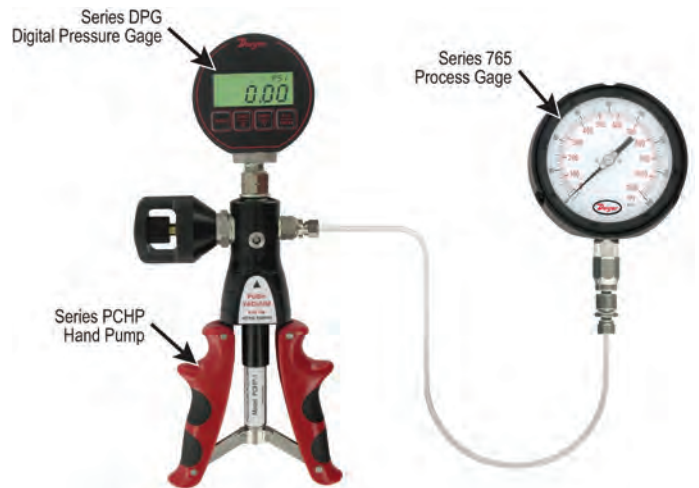

**Field calibrate and certify pressure gages**

Using the Series PCHP with a Series DPG-100, a technician can calibrate or certify process pressure gages up to 1% accurate. The Model PCHP-1 hand pump can easily supply pressures up to 600 PSI by squeezing the handle and adjusting the volume control valve. The pump has two connections to be connected with a test gage, such as the Dwyer® Series DPG-100, and a process gage, such as the Dwyer® Series 765.



### Digital manometers used to check gas pressure to a heating burner

Checking the gas pressure to a heating unit on the burner side of the regulator is a standard installation and service routine. The Dwyer® Series 475 handheld digital manometer is a low-cost, durable device that is easily transportable in a pocket or briefcase. Units are highly accurate with 0.5% full-scale accuracy. Some servicemen prefer our portable Dwyer® Magnehelic® differential pressure gage with dial type scale for field use.

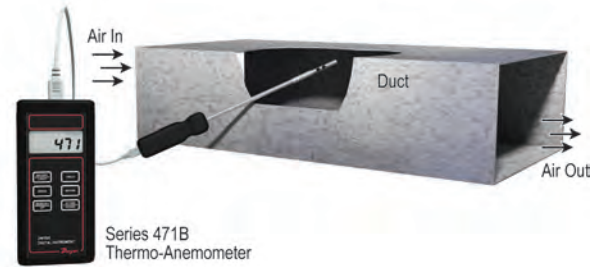

### Determine air velocity and temperature levels in ducts or air supply grills

The Dwyer® Series 471B digital thermo-anemometer is the ideal portable product for determining air velocity and temperature levels in ducts or air supply grills. With a push of a button, FPM and Fahrenheit readings are converted to MPS and Celsius. Readings may be stored and retrieved which allows the user greater efficiency with HVAC balancing at various locations in a building.

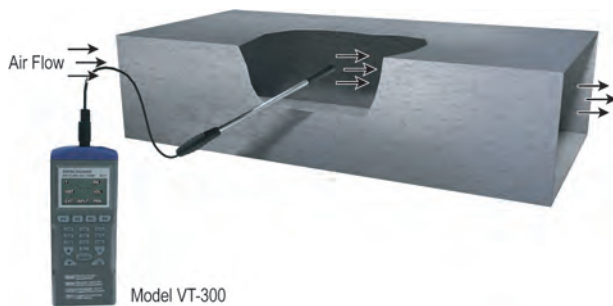

### Handheld anemometer enables measuring duct flow measurements

Handheld anemometers are an excellent, portable tool for performing tests on HVAC system performance; however, large rotating vanes can prevent easy access to ducts. Dwyer introduces the VT-300 mini-vane thermo-anemometer to eliminate this problem. Additionally, simple keypad programming enables the user to view volumetric flow rates in CFM or CMM.



### Quickly measure humidity and temperature levels in ambient air

The Dwyer® Model 485B-1 thermo-hygrometer is a simple, portable device for quickly measuring humidity and temperature levels in ambient air. The dew point and wet-bulb temperature readings are derived from relative humidity and temperature measurements. The Model 485B-1 is often used in agricultural applications where proper humidity and temperature levels are critical in plant or animal well being.

# AIR VELOCITY MEASUREMENT

## INTRODUCTION

In air conditioning, heating and ventilating work, it is helpful to understand the techniques used to determine air velocity. In this field, air velocity (distance traveled per unit of time) is usually expressed in feet per minute (FPM). By multiplying air velocity by the cross section area of a duct, you can determine the air volume flowing past a point in the duct per unit of time. Volume flow is usually measured in cubic feet per minute (CFM).

Velocity or volume measurements can often be used with engineering handbook or design information to reveal proper or improper performance of an airflow system. The same principles used to determine velocity are also valuable in working with pneumatic conveying, flue gas flow and process gas systems. However, in these fields the common units of velocity and volume are sometimes different from those used in air conditioning work.

To move air, fans or blowers are usually used. They work by imparting motion and pressure to the air with either a screw propeller or paddle wheel action. When force or pressure from the fan blades causes the air to move, the moving air acquires a force or pressure component in its direction of motion due to its weight and inertia. Because of this, a flag or streamer will stand out in the air stream. This force is called velocity pressure. It is measured in inches of water column (w.c.) or water gage (w.g.). In operating duct systems, a second pressure is always present. It is independent of air velocity or movement. Known as static pressure, it acts equally in all directions. In air conditioning work, this pressure is also measured in inches w.c.

In pressure or supply systems, static pressure will be positive on the discharge side of the fan. In exhaust systems, a negative static pressure will exist on the inlet side of the fan. When a fan is installed midway between the inlet and discharge of a duct system, it is normal to have a negative static pressure at the fan inlet and positive static pressure at its discharge.

Total pressure is the combination of static and velocity pressures, and is expressed in the same units. It is an important and useful concept to use because it is easy to determine and, although velocity pressure is not easy to measure directly, it can be determined easily by subtracting static pressure from total pressure. This subtraction need not be done mathematically. It can be done automatically with the instrument hook-up.

## SENSING STATIC PRESSURE

For most industrial and scientific applications, the only air measurements needed are those of static pressure, total pressure and temperature. With these, air velocity and volume can be quickly calculated.

To sense static pressure, six types of devices are commonly used. These are connected with tubing to a pressure indicating instrument. Fig. 1-A shows a simple thru-wall static pressure tap. This is a sharp, burr-free opening through a duct wall provided with a tubing connection of some sort on the outside. The axis of the tap or opening must be perpendicular to the direction of flow. This type of tap or sensor is used where air flow is relatively slow, smooth and without turbulence. If turbulence exists, impingement, aspiration or unequal distribution of moving air at the opening can reduce the accuracy of readings significantly.

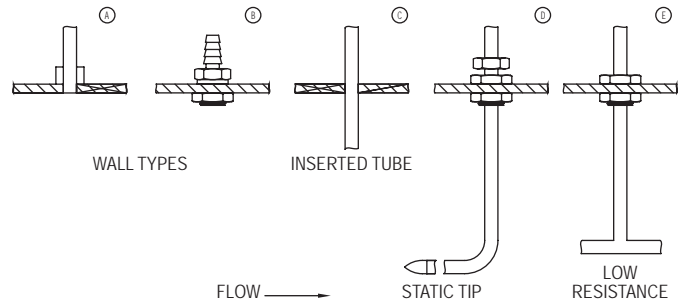

Figure 1 - Types of static pressure devices

Fig. 1-B shows the Dwyer® No. A-308 Static Pressure Fitting. Designed for simplified installation, it is easy to install, inexpensive, and provides accurate static pressure sensing in smooth air at velocities up to 1500 FPM.

Fig. 1-C shows a simple tube through the wall. Limitations of this type are similar to wall type Fig. 1-A.

Fig. 1-D shows a static pressure tip which is ideal for applications such as sensing the static pressure drop across industrial air filters and refrigerant coils. Here the probability of air turbulence requires that the pressure sensing openings be located away from the duct walls to minimize impingement and aspiration and thus ensure accurate readings. For a permanent installation of this type, the Dwyer® No. A-301 or A-302 Static Pressure Tip is used. It senses static pressure through radially-drilled holes near the tip and can be used in air flow velocities up to 12,000 FPM.

Fig. 1-E shows a Dwyer® No. A-305 low resistance Static Pressure Tip. It is designed for use in dust-laden air and for rapid response applications. It is recommended where a very low actuation pressure is required for a pressure switch or indicating gage — or where response time is critical.

## MEASURING TOTAL PRESSURE AND VELOCITY PRESSURE

In sensing static pressure we make every effort to eliminate the effect of air movement. To determine velocity pressure, it is necessary to determine these effects fully and accurately. This is usually done with an impact tube which faces directly into the air stream. This type of sensor is frequently called a “total pressure pick-up” since it receives the effects of both static pressure and velocity pressure.

# AIR VELOCITY MEASUREMENT

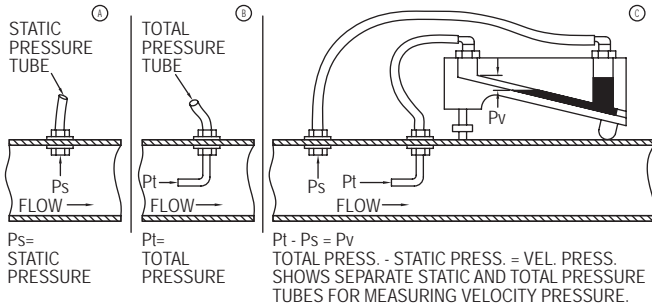

Figure 2 - Types of pressure measurements

In Figure 2, note that separate static connections (A) and total pressure connections (B) can be connected simultaneously across a manometer (C). Since the static pressure is applied to both sides of the manometer, its effect is cancelled out and the manometer indicates only the velocity pressure.

To translate velocity pressure into actual velocity requires either mathematical calculation, reference to charts or curves, or prior calibration of the manometer to directly show velocity. In practice this type of measurement is usually made with a Pitot tube which incorporates both static and total pressure sensors in a single unit.

Essentially, a Pitot tube consists of an impact tube (which receives total pressure input) fastened concentrically inside a second tube of slightly larger diameter which receives static pressure input from radial sensing holes around the tip. The air space between the inner and outer tubes permits transfer of pressure from the sensing holes to the static pressure connection at the opposite end of the Pitot tube and then, through connecting tubing, to the low or negative pressure side of a manometer. When the total pressure tube is connected to the high pressure side of the manometer, velocity pressure is indicated directly. See Figure 3.

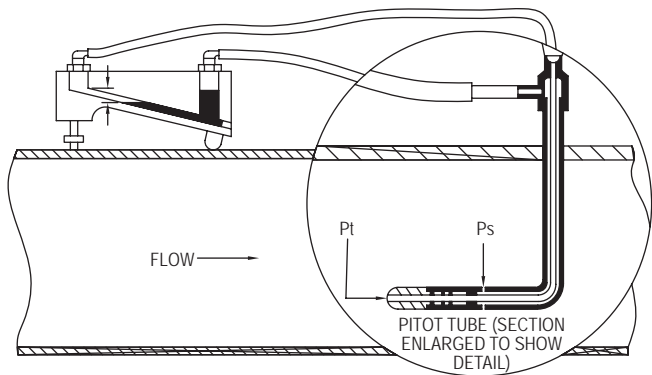

Figure 3 - Pitot tube senses total and static pressures. Manometer measures velocity pressure – (difference between total and static pressures).

Since the Pitot tube is a primary standard device used to calibrate all other air velocity measuring devices, it is important that great care be taken in its design and fabrication. In modern Pitot tubes, proper nose or tip design — along with sufficient distance between nose, static pressure taps and stem — will minimize turbulence and interference. This allows use without correction or calibration factors. All Dwyer® Pitot tubes are built to AMCA and ASHRAE standards and have unity calibration factors to assure accuracy.

To ensure accurate velocity pressure readings, the Pitot tube tip must be pointed directly into (parallel with) the air stream. As the Pitot tube tip is parallel with the static pressure outlet tube, the latter can be used as a pointer to align the tip properly. When the Pitot tube is correctly aligned, the pressure indication will be maximum.

Because accurate readings cannot be taken in a turbulent air stream, the Pitot tube should be inserted at least 8-1/2 duct diameters downstream from elbows, bends or other obstructions which cause turbulence. To ensure the most precise measurements, straightening vanes should be located 5 duct diameters upstream from the Pitot tube.

## HOW TO TAKE TRAVERSE READINGS

In practical situations, the velocity of the air stream is not uniform across the cross section of a duct. Friction slows the air moving close to the walls, so the velocity is greater in the center of the duct.

To obtain the average total velocity in ducts of 4" diameter or larger, a series of velocity pressure readings must be taken at points of equal area. A formal pattern of sensing points across the duct cross section is recommended. These are known as traverse readings. Figure 4 shows recommended Pitot tube locations for traversing round and rectangular ducts.

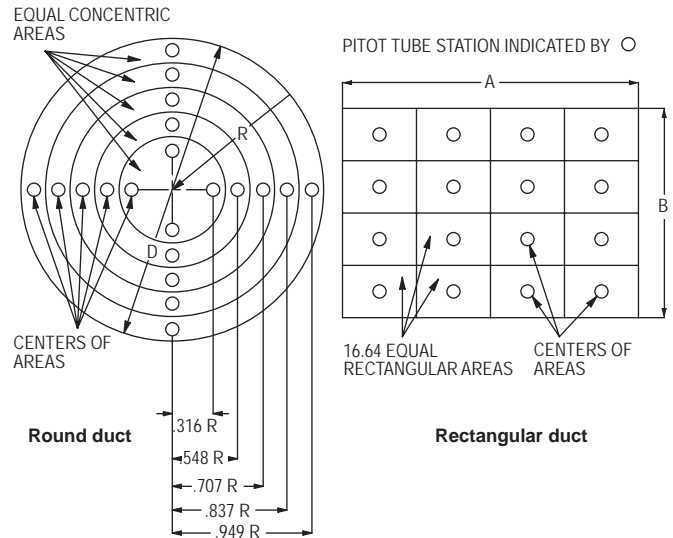

Figure 4 - Traverse on round and rectangular duct areas

In round ducts, velocity pressure readings should be taken at centers of equal concentric areas. At least 20 readings should be taken along two diameters. In rectangular ducts, a minimum of 16 and a maximum of 64 readings are taken at centers of equal rectangular areas. Actual velocities for each area are calculated from individual velocity pressure readings. This allows the readings and velocities to be inspected for errors or inconsistencies. The velocities are then averaged.

By taking Pitot tube readings with extreme care, air velocity can be determined within an accuracy of ±2%. For maximum accuracy, the following precautions should be observed:

1. Duct diameter should be at least 30 times dia. of Pitot tube.
2. Locate the Pitot tube in a duct section providing 8-1/2 or more duct diameters upstream and 1-1/2 or more diameters downstream of Pitot tube free of elbows, size changes or obstructions.
3. Provide an egg-crate type of flow straightener 5 duct diameters upstream of Pitot tube.
4. Make a complete, accurate traverse.

In small ducts or where traverse operations are otherwise impossible, an accuracy of ±5% can frequently be achieved by placing Pitot tube in center of duct. Determine velocity from the reading, then multiply by 0.9 for an approximate average.

# AIR VELOCITY MEASUREMENT



## CALCULATING AIR VELOCITY FROM VELOCITY PRESSURE

Manometers for use with a Pitot tube are offered in a choice of two scale types. Some are made specifically for air velocity measurement and are calibrated directly in feet per minute. They are correct for standard air conditions: i.e. air density of .075 lb per ft<sup>3</sup> corresponds to dry air at 70°F, barometric pressure of 29.92 inches Hg. To correct the velocity reading for other than standard air conditions, the actual air density must be known. It may be calculated if relative humidity, temperature and barometric pressure are known.

Most manometer scales are calibrated in inches of water. Using readings from such an instrument, the air velocity may be calculated using the basic formula:

$$V = 1096.7 \sqrt{\frac{h_v}{d}} \left\{ = 4004.4 \sqrt{h_v} \text{ for } .075 \text{ lb/ft}^3 \text{ dry air @ } 70^\circ\text{F, } 29.92 \text{ in. Hg Baro.} \right\}$$

Where: V = Velocity in feet per minute.  
 $h_v$  = Velocity pressure in inches of water.  
 d = Density of air in pounds per cubic foot.

To determine dry air density, use the formula:

$$d = 1.325 \frac{P_B}{T}$$

Where: d = Air density in pounds per cubic foot.

$$P_B = \left\{ \begin{array}{l} \text{Barometric (or absolute) static pressure in inches of mercury.} \\ T = \text{Absolute temperature (indicated temperature in } ^\circ\text{F plus } 460^\circ). \end{array} \right\}$$

With dry air at 29.9 inches mercury, air velocity can be read directly from curves on the following page. For partially or fully saturated air a further correction is required. To save time when converting velocity pressure into air velocity, the Dwyer® Air Velocity Calculator may be used. A simple slide rule, it provides for all the factors needed to calculate air velocity quickly and accurately. It is included as an accessory with each Dwyer® Pitot tube.

To use the Dwyer® Calculator:

1. Set relative humidity on scale provided. On scale opposite known dry bulb temperature, read correction factor.
2. Set temperature under barometric pressure scale. Read density of air over correction factor established in 1 (above).
3. On the other side of calculator, set air density reading just obtained on the scale provided.
4. Under Pitot tube reading (velocity pressure, inches of water) read air velocity, feet per minute.

## DETERMINING VOLUME FLOW

Once the average air velocity is known, the air flow rate in cubic feet per minute is easily computed using the formula:

$$Q = AV$$

Where: Q = Quantity of flow in cubic feet per minute.  
 A = Cross sectional area of duct in square feet.  
 V = Average velocity in feet per minute.

## DETERMINING AIR VOLUME BY CALIBRATED RESISTANCE

Manufacturers of air filters, cooling and condenser coils and similar equipment often publish data from which approximate air flow can be determined. It is characteristic of such equipment to cause a pressure drop which varies proportionately to the square of the flow rate. Figure 5 shows a typical filter and a curve for air flow versus resistance. Since it is plotted on logarithmic paper, it appears as a straight line. On this curve, a clean filter which causes a pressure drop of .50 in w.c. would indicate a flow of 2,000 c.f.m.

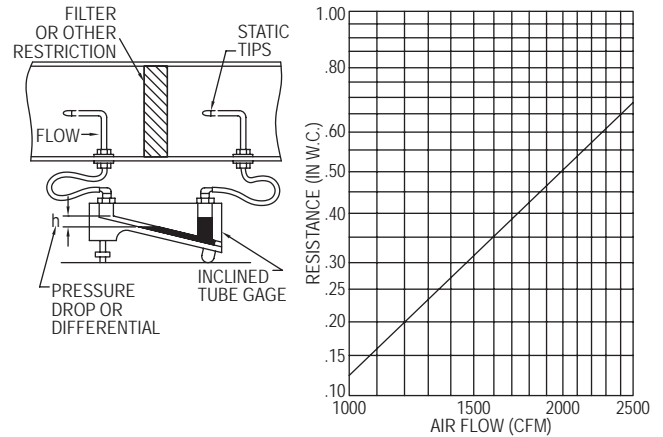

Figure 5 - Differential measurement across duct restriction

For example, assuming a manufacturer's specification for a filter, coil, etc:

Given Flow Q (ft<sup>3</sup>/min.) = at differential "h" (inches w.c.)

To determine flow at other differentials the formula is:

$$Q_n (\text{other flows}) = Q \sqrt{\frac{h_n}{h}}$$

Where: Q = Quantity of flow in cubic feet per minute  
 h = Differential in inches water column  
 $h_n$  = Differential (other flow conditions)

## OTHER DEVICES FOR MEASURING AIR VELOCITY

A wide variety of devices are commercially available for measuring air velocities. These include hot wire anemometers for low air velocities, rotating and swinging vane anemometers and variable area flowmeters.

The Dwyer® No. 460 Air Meter is one of the most popular and economical variable area flowmeter type anemometers. Quick and easy to use, it is a portable instrument calibrated to provide a direct reading of air velocity.

A second scale is provided on the other side of the meter to read static pressure in inches w.c. The 460 Air Meter is widely used to determine air velocity and flow in ducts, and from supply and return grilles and diffusers. Two scale ranges are provided (high and low) with calibrations in both f.p.m. and in w.c.

## TO CHECK ACCURACY

Use only devices of certified accuracy. All anemometers and to a lesser extent portable manometers should be checked regularly against a primary standard such as a hook gage or high quality micromanometer. If in doubt return your Dwyer® instrument to the factory for a complete calibration check at no charge.

## HVAC MOBILE APPLICATION

Easily converts velocity pressure to air velocity or air velocity to air volume for most Android® or iOS devices.

## FREE DOWNLOAD!

Download the phone app of our Air Velocity and Flow Calculator on our website at [www.dwyer-inst.com/flowcalcapp/](http://www.dwyer-inst.com/flowcalcapp/)

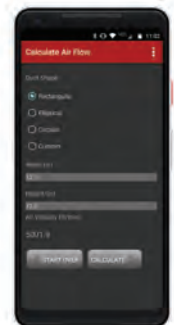



# AIR VELOCITY FLOW CHARTS

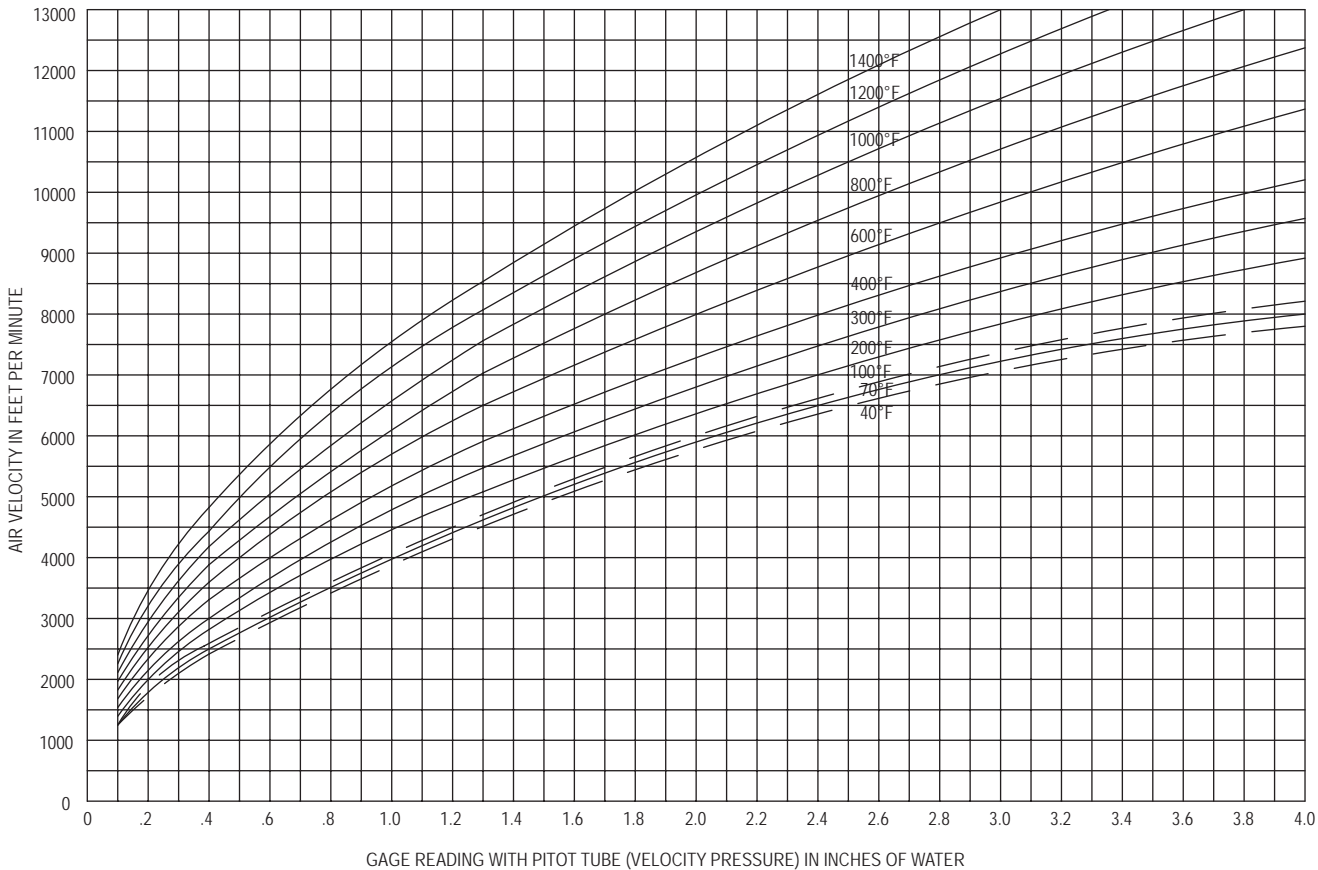
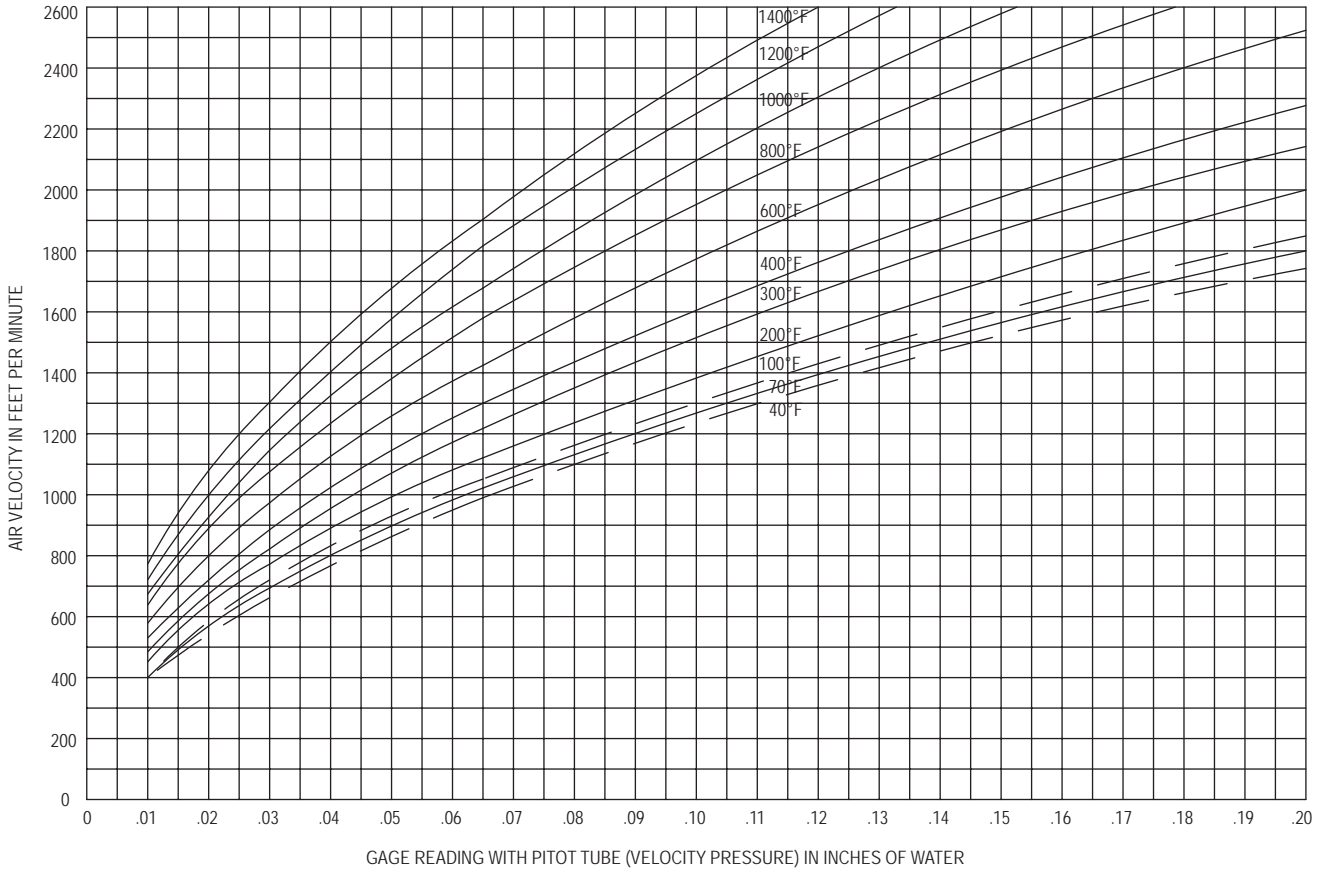

# AIR BALANCING HVAC SYSTEMS

## METHODS OF AIR BALANCING

Air balancing a distribution system is needed to properly direct the air flow in order to optimize the system's design. Flow rates are tested, adjusted, and balanced as cubic feet per minute (CFM) or cubic meters per hour (m<sup>3</sup>/h). There are two traditional methods for balancing airflow at the terminals. The first is sequential balancing, which involves setting the zone and branch dampers in sequence. However, the most common method of air balancing is called proportional balancing.

For traditional proportional balancing, an air flow hood, or capture hood, is the most popular test instrument used to take air flow readings. Traverse readings in the duct with a Pitot tube or a hot-wire thermo-anemometer is another accepted method of capturing the actual air flow.

Dwyer has designed a variation of proportional balancing, which is called Predictive Balancing used in Dwyer's Series SAH SMART Air Hood® Balancing Instrument. Predictive Balancing is designed to be a faster process and give more accurate results than traditional proportional balancing.

## PREDICTIVE VS PROPORTIONAL BALANCING

In traditional proportional balancing, the flow hood will directly measure volumetric air flow at the outlets or terminals of a system: the registers, grilles, and diffusers. Most air flow hoods are cone shaped and aligned to the ceiling registers as shown in Figure 1 in the left picture. When a flow hood is placed over a terminal, it will generate pressure within the duct system, which reduces the air flow to the terminal. This condition is called back pressure. The effect of back pressure can result in errors when taking readings. Before using a flow hood, many technicians recommend performing a duct traverse to verify the K factor. Some digital flow hoods include back pressure compensation that attempts to calculate the effect of backpressure for the technician.

Dwyer's Predictive Balancing technique is based on mass balance and energy conservation methods. Predictive Balancing, is a process that involves predicting the ideal flow set points for each TUA (Terminal Under Adjustment) so that every terminal is at the target flow until the process is complete. Dwyer's Series SAH SMART Air Hood® Balancing Instrument was designed with Predictive Balancing in mind. Dwyer's air hood is being used in Figure 1 in the right picture.

Predictive Balancing is deterministic and minimizes the number of process steps involved in testing, adjusting, and balancing HVAC systems. Figure 2 illustrates a comparison between Predictive Balancing and traditional proportional balancing processes, showing how much faster Predictive Balancing is.



Figure 1 – Traditional air flow hood (left picture) versus Dwyer SMART Air Hood® balancing instrument (right picture)

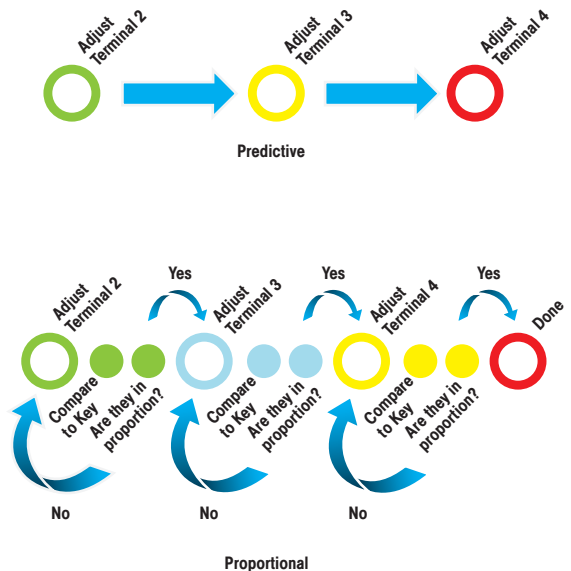

Figure 2 – Predictive vs Proportional Balancing



# AIR BALANCING HVAC SYSTEMS

## PROPORTIONAL BALANCING

With proportional balancing (reference Figure 3), the technician balances a terminal proportional to the key terminal. To start a proportional balance of a system, one requirement is that the system has an 80% to 120% rate to the total design flow. Systems that are higher or lower than this range will not balance properly. If the system is outside of this range, the fan speed should be adjusted to get within range. Once set, the air flow from each terminal will remain the same ratio to other terminals.

If key Terminal 1 has a design flow percent of 60%, then Terminal 2 is 57%, Terminal 3 is 65%, and the ratio to the key Terminal 1 is  $57\% / 60\% = 0.95$ . Meaning Terminal 2 will deliver 95% of the air volume of Terminal 1. With Terminal 1 as the key, delivering 100% of design flow, then Terminal 2 will be delivering 95% of the design flow. This will meet the design requirements. For example, if the damper for Terminal 3 is adjusted down to 525 CFM, the flow from Terminal 1 may increase to 550 CFM. In this case, Terminal 2 is within the design range;  $550 * 0.95 = 523$  CFM.

Once the terminals are in balance, with the proper ratio of tolerance with each other, they remain in balance with each other even though the air volume may change. All terminals in the system are then proportionally balanced. The fan RPM can be set to deliver the intended total air volume and all terminals will deliver the design flow within the established tolerances.

This process requires the balancing technician to adjust the flow from the terminal under-adjustment (TUA) to the key to gain the correct flow proportion. The key terminal's flow changes when the TUA damper is changed. It may take several iterations to achieve the proper flow proportion.

Since the technician is estimating where to set the flow rate of the TUA relative to the key, the tolerance can vary considerably, which limits the accuracy of the balancing. The illustration in Figure 3 shows the potential number of lengthy steps involved with proportional balancing.

## PREDICTIVE BALANCING

The Predictive Balancing (reference Figure 4) process begins by opening the dampers to capture the total flow. The total flow is distributed into the four terminal flows. The terminal flows are determined by the terminal and damper loads and the pressure drop in the system.

Terminal 2 is the first damper adjusted in the system, and Terminal 1 is the key. Predictive Balancing calculates the ideal flow set point for Terminal 2 for TUA and predicts flows for Terminals 1, 3, and 4.

After adjusting the Terminal 2 flow to the ideal flow set point, Predictive Balancing calculates the ideal set point for Terminal 3 and predicts the new flows for terminals 1, 2, and 4.

To finish, Predictive Balancing calculates the ideal set point for the last Terminal, number 4, and flows for Terminals 1, 2, and 3 are correctly proportioned to the target.

Finally, Predictive Balancing calculates the ideal flow for Terminal 4 so the blower flow can be adjusted to bring all the terminal flows to the target flows.

Predictive Balancing also monitors and compensates for load on the blower/fan from the damper closures during the balancing process. The illustration in Figure 4 compared to Figure 3 shows just how much easier and faster Predictive Balancing is over Proportional Balancing in the amount of steps involved in the process.

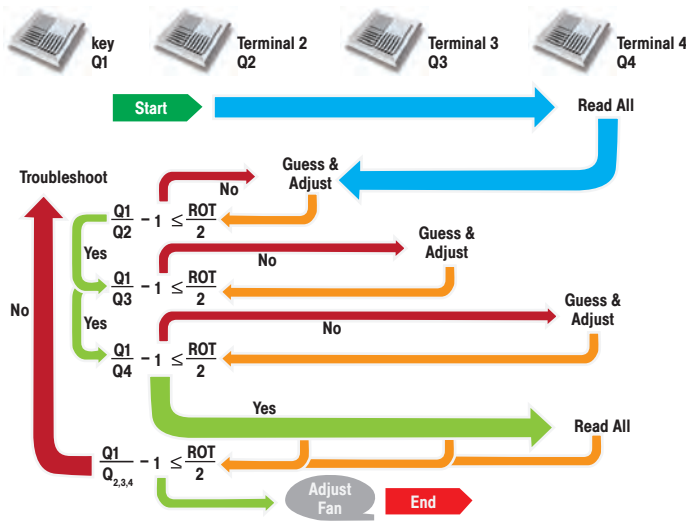

Figure 3 – Proportional balancing

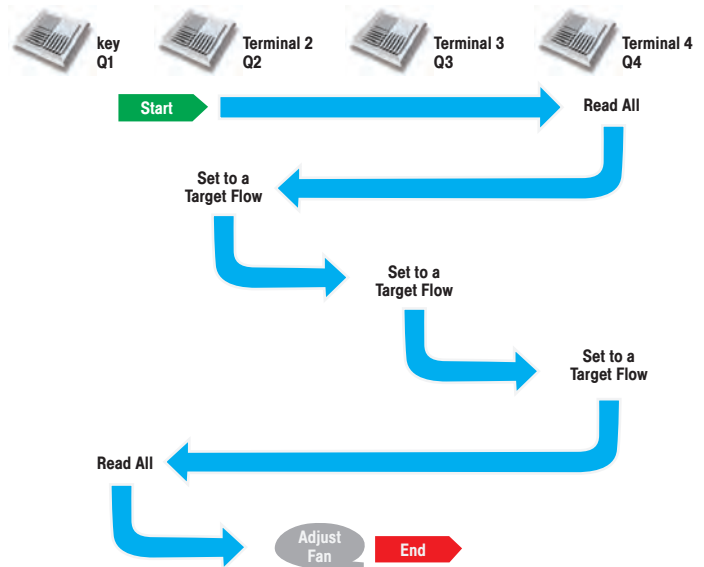
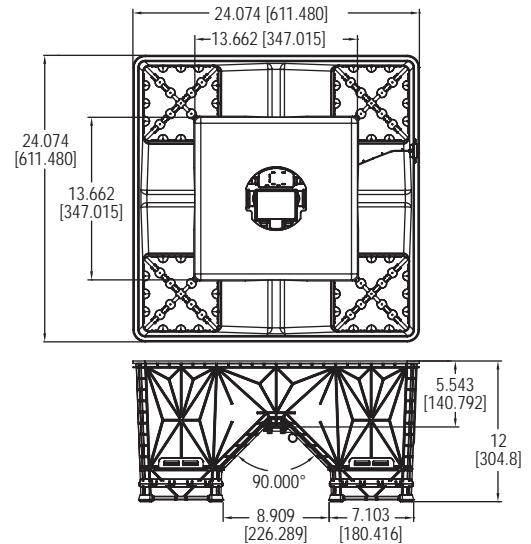

Figure 4 – Predictive balancing

**Dwyer**  
SERIES SAH

# SMART AIR HOOD® BALANCING INSTRUMENT

Quad Flow Design Technology, Predictive Balancing



The **Series SAH SMART Air Hood® Balancing Instrument** is the most accurate and easy to operate air flow hood on the market. By using the included hood stand and wireless communications to the handheld, a single operator can balance a branch in less time than traditional balancing teams. Besides being lighter than most traditional capture hoods, the ergonomic design makes the Series SAH easy to maneuver, with less physical stress. The rugged polypropylene base hood features patented Quad Flow Design Technology for controlling air flow and minimizing back pressure, which yields superior measurement accuracy. The Wi-Fi direct communication gives reliable communication with a distance of up to 200 yards (183 m) between the hood and the handheld test instrument. The SMART Air Hood® balancing instrument includes the SMART Air Hood® Application Software which reduces the number of steps in the air flow balancing process using Predictive Balancing's Express Balance mode. Predictive Balancing is a method of predicting the optimal flow set point for each register and the order in which they should be adjusted.

## FEATURES/BENEFITS

- Patent pending Quad Flow Design Technology directs the circulating air patterns to provide a more even air flow that minimizes backpressure enabling accurate readings
- Patent pending Predictive Balancing is a process that guides the balancing technician on setting the optimal flow set point for each sequential terminal. With the SMART Air Hood® Application Software, the balancing process takes much less time than traditional air balancing methods
- The ergonomic design is much lighter and easier to work with than the existing bulky air hoods, providing greater maneuverability and less physical strain. One technician can complete the air balancing
- Wi-Fi direct wireless communication provides a range up to 200 yards (183 m) line of sight

## APPLICATIONS

- Commissioning, testing, adjusting and balancing volumetric air flow from diffusers, grilles, and registers in HVAC systems

## INCLUDED WITH THE SAH-22-IN:

- Handheld Test Instrument preloaded with SMART Air Hood® App
- 3' (0.9 m) extendable pole
- Handheld quick release pole adapter kit
- SAH roller travel case with instrument available foam inserts
- Charging cables for SAH and handheld
- Lithium ion battery
- Installation and operating manual
- NIST traceable certificate

## SPECIFICATIONS

### SAH SPECIFICATIONS

**Service:** Air.

**Units:** CFM, m<sup>3</sup>/h, l/s.

**Volume Flow Ranges:** Supply: 40 to 2000 CFM (68 to 3398 m<sup>3</sup>/h) (19 to 944 l/s); Exhaust: 80 to 2000 CFM (136 to 3398 m<sup>3</sup>/h) (38 to 944 l/s).

**Accuracy > 40 CFM:** ±3% of reading ±7 CFM (11.9 m<sup>3</sup>/hr) (3.3 l/s).

**Resolution:** 1 CFM (1.7 m<sup>3</sup>/h) (.5 l/s).

**Power Requirements:** 3.6 V NCR18650B MH12210 lithium ion battery, included, user replaceable or (4) 1.5 V AA alkaline batteries, not included, user replaceable.

**Housing Material:** Polypropylene.

**Weight:** 5.75 lb (2.6 kg).

**Agency Approvals:** CE, FCC, IC.

### HANDHELD SPECIFICATIONS

**Operating System:** SMART Air Hood® Application Software only available with factory supplied test instrument.

**Wireless Protocol:** Wi-Fi direct low energy wireless technology.

**Response Time:** 1 s.

Updates to diffuser library can be downloaded using Google Play™ store.

## MODEL CHART

Model	Description
SAH-22	SMART Air Hood® balancing instrument with 2' x 2' (0.6 m x 0.6 m) opening
A-SAH-12P	4.5' to 12' (1.4 m x 3.7 m) extendable pole ( <b>Required for operation</b> )
SAH-22HC	SMART Air Hood® balancing instrument with 2' x 2' (0.6 m x 0.6 m) opening, with hard travel case

## ACCESSORIES

Model	Description
A-SAH-14S	Canvas hood 1' x 4' (0.3 m x 1.2 m)
A-SAH-24S	Canvas hood, 2' x 4' (0.6 m x 1.2 m)
A-SAH-33S	Canvas hood, 3' x 3' (0.9 m x 0.9 m)
A-SAH-15S	Canvas hood, 1' x 5' (0.3 m x 1.5 m)
A-SAH-BK	SAH adapter base kit for canvas hood
A-SAH-CK	Spare calibration kit with four quad flow sensing grids and sensor module
A-SAH-12P	4.5' to 12' (1.4 m x 3.7 m) extendable pole
A-SAH-22HC	Hard carrying case for SAH

**Note:** For full functionality and versatility, the A-SAH-12P is required for operation of all SAH models.

Google Play™ is a trademark of Google, Inc.

# TEST, ADJUST, AND BALANCE KIT

## A Complete Balancing Technician Solution

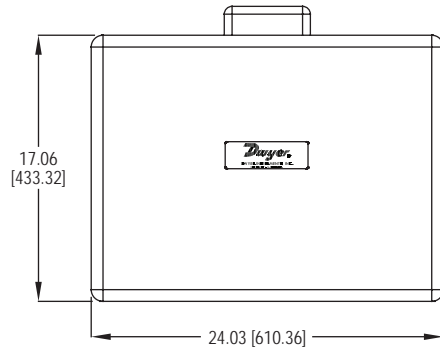

### WHAT'S INCLUDED



The **Series TABKIT Test, Adjust, and Balance Kit** combines all essential air, water, temperature, humidity, and electrical test instruments are included in this kit, creating the ultimate air and water balancing solution. The Series TABKIT has everything a balancing technician needs in a single case. A certificate of NIST calibration is included for each instrument inside the kit, ensuring accurate, durable, repeatable, and reliable measurements every time. When the products need to be recalibrated, save time by sending everything back to Dwyer. Our lab is able to service all equipment within the kit, and ensure they're as accurate as the day you originally received them.

### FEATURES/BENEFITS

- Everything a balancing technician needs in a single case
- Best in class low flow velocity readings
- Repeatable measurements

### APPLICATIONS

- Building balancing
- Building commissioning
- Testing HVAC equipment performance

MODEL CHART	
Model	Description
TABKIT-NIST	Complete NIST calibrated test, adjust, and balance kit with hard carrying case.

### SPECIFICATIONS

**AIR**  
**SERIES DP3**  
**Accuracy\*:** ±0.5% FS span @ 25°C (includes non linearity, hysteresis, and non repeatability).  
**Pressure Limits:** ±10 in w.c. (±2.5 kPa).  
**Temperature Limits:** Operating: -4 to 140°F (-20 to 60°C); Storage: -40 to 185°F (-40 to 85°C).

**MODEL AP3**  
**Range:** Air velocity: 0 to 6000 FPM (0 to 30 m/s); Volumetric air: 999,999 in selected flow units; Temperature: -20 to 212°F (-29 to 100°C).  
**Accuracy:** Air velocity\*: ±3% FS within temperature range of 40 to 90°F (4 to 32°C) -TAB option: 50 to 3900 FPM (0.25 to 20 m/s); Temperature: ±0.5°F (±0.28°C).

**MODEL VP3**  
**Range:** Air velocity: 40 to 5000 FPM (0.2 to 25 m/s); Volumetric air: 999,999 in selected flow units; Temperature: -20 to 212°F (-29 to 100°C); Relative humidity: 0 to 100% RH.  
**Accuracy:** Air velocity\*: 0.25 to 10 m/s: ±1.5% of reading ±20 FPM (±0.1 m/s); 10 to 20 m/s: 1.5% of reading ±40 FPM (±0.2 m/s); 20 to 25 m/s: ±1.5% of reading ±60 FPM (±0.3 m/s); Temperature: ±0.54°F @ 77°F (±0.3°C @ 25°C); Relative humidity: ±2% @ 77°F (25°C) (10 to 90% RH); ±4% (0 to 10% RH and 90 to 100%).  
**Resolution:** 1 FPM (0.001 m/s).

**TEMPERATURE**  
**MODEL TM99A and SERIES 1075**  
**Range:** 0 to 200°F (-20 to 100°C).  
**Accuracy\*:** ±0.5% of reading + 2.0°F (±0.5% of reading + 1.0°C).  
**Resolution:** 0.1°F (0.1°C).

\*NIST calibrated.  
**Note:** See website for more detailed specifications.  
**Note:** Instruments meet or exceed NEBB requirements.

**HUMIDITY**  
**MODEL RP3**  
**Range:** RH: 0 to 100% (non-condensing); Temperature: -22 to 140°F (-30 to 60°C).  
**Accuracy:** RH\*: ±2% @ 25°C (10 to 90% RH); ±4% (0 to 10, 90 to 100% RH); Temperature: ±0.54°F @ 77°F (±0.3°C).

**ELECTRICAL**  
**MODEL CM-1\***  
**AC Voltage:** 0.1-600 V ± (1.0% + 5 dgt).  
**DC Voltage:** 0.1-600 V ± (1.0% + 3 dgt).  
**AC Current:** 0.1-400 A ± (2.0% + 10 dgt).  
**Resistance:** 0.1-400 Ω ± (1.0% + 5 dgt).

**ROTATION**  
**MODEL TAC-L**  
**Range:** Non-contact (RPM): 2.5 to 99,999 RPM; Contact (RPM): 0.5 to 19,999 RPM; Surface speed (m/min): 0.05 to 19,999 m/min.  
**Resolution:** Non-contact\* (RPM): 0.1 RPM (2.5 to 999.9 RPM), 1 RPM (1000 to 19,000 RPM); Surface speed (m/min): 0.01 m/min (0.05 to 99.99 m/min), 0.1 m/min (100.0 to 1999.9 m/min).

**HYDRONIC**  
**A-490W-6**  
**Range:** 0.4 to 200 psi (3 to 1400 kPa); 0.4 to 75 psi (3 to 500 kPa).  
**Accuracy\*:** 2% of reading ±1 psi (2% of reading ±7 kPa); 2% of reading ±0.5 psi (2% of reading ±3.5 kPa).  
**Resolution:** 0.1 psi (1.0 kPa); 0.01 psi (0.1 kPa).

USA: California Proposition 65  
⚠WARNING: Cancer and Reproductive Harm - www.P65Warnings.ca.gov

Dwyer

MODEL RP3

CE



# THERMO-HYGROMETER PROBE

Wireless, Measures Humidity, Temperature, Dew Point, and Wet Bulb Temperatures

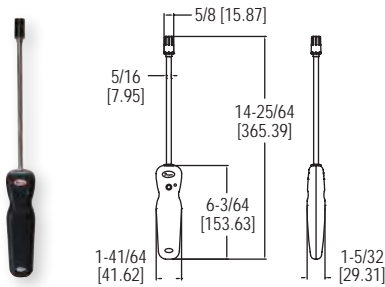

## FEATURES/BENEFITS

- Allows for one handed operation for ladder use safety
- Stable 50 ft (15 m) wireless range

## APPLICATIONS

- Building commissioning
- Building HVAC test and balance

## SPECIFICATIONS

**Service:** Clean air.  
**Temperature Limits:** Process: -4 to 140°F (-20 to 60°C); Ambient: 5 to 125°F (-15 to 51°C).  
**Battery Charging:** 32 to 113°F (0 to 45°C).  
**Range:** RH: 0 to 100% (non-condensing); Temperature: -22 to 140°F (-30 to 60°C).  
**Accuracy:** RH: ±2% @ 25°C (10 to 90% RH); ±4% (0 to 10, 90 to 100% RH); Temperature: ±0.54°F @ 77°F (±0.3°C @ 25°C).

**Response Time:** 1.5 s.  
**Probe Length:** 8" (203 mm) insertion.  
**Power Requirements:** 3.7 V YT562447 Lithium ion battery.  
**Maximum Wireless Distance:** 50' (15 m).  
**Handle Enclosure:** Thermoplastic elastomer over polycarbonate.  
**Supplied With:** Wrist strap.  
**Weight:** 11.2 oz (331.22 g).  
**Agency Approvals:** CE (not while charging), FCC compliant.

## MODEL CHART

Model	Description
RP3	Wireless thermo-hygrometer probe for use with the Model UHH4 or newer Universal Handheld device, or personal smart device with Mobile Meter® Software.

## SERIES AP3

# THERMO-ANEMOMETER PROBE

Wireless, Measures Velocity, Flow, and Temperature

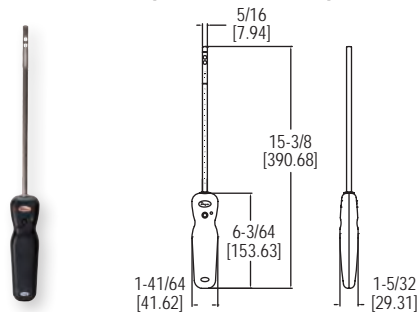

## FEATURES/BENEFITS

- Allows for one handed operation for ladder use safety
- Stable 50 ft (15 m) wireless range

## APPLICATIONS

- Building commissioning
- Building HVAC test and balance

## SPECIFICATIONS

**Service:** Dry, clean air.  
**Temperature Limits:** Process: -20 to 212°F (-29 to 100°C); Ambient: 5 to 125°F (-15 to 51°C).  
**Range:** Air velocity: 0 to 6000 FPM (0 to 30 m/s); Volumetric air: 999,999 in selected flow units; Temperature: -20 to 212°F (-29 to 100°C).  
**Accuracy:** Air velocity: ±3% FS within temperature range of 40 to 90°F (4 to 32°C) -TAB option: 50 to 3900 FPM (0.25 to 20m/s); Temperature: ±0.5°F (±0.28°C).  
**Response Time:** 1 s.

**Probe Length:** 8" (203 mm) insertion (See model chart for optional probe lengths).  
**Battery Charging Limits:** 32 to 113°F (0 to 45°C).  
**Power Requirements:** 3.7 V YT562447 Lithium ion battery.  
**Maximum Wireless Distance:** 50' (15 m).  
**Handle Enclosure:** Thermoplastic elastomer over polycarbonate.  
**Supplied With:** Wrist strap.  
**Weight:** 11.2 oz (317 g).  
**Agency Approvals:** CE (not while charging), FCC compliant.

## MODEL CHART

Model	Probe Length
AP3	8" (203.2 mm)
AP3-18	18" (457.2 mm)
AP3-24	24" (609.6 mm)
AP3-36	36" (914.4 mm)

## SERIES VP3

# 100 MM VANE THERMO-ANEMOMETER PROBE

Wireless, Measures Velocity, Flow, Humidity, and Temperature

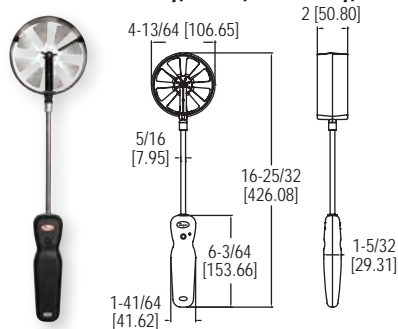

## FEATURES/BENEFITS

- Allows for one handed operation for ladder use safety
- Stable 50 ft (15 m) wireless range

## APPLICATIONS

- Building commissioning
- Building HVAC test and balance

## SPECIFICATIONS

**Service:** Dry, clean air.  
**Temperature Limits:** Process: -20 to 212°F (-29 to 100°C); Ambient: 5 to 125°F (-15 to 51°C).  
**Range:** Air velocity: 40 to 5000 FPM (0.2 to 25 m/s); Volumetric air: 999,999 in selected flow units; Temperature: -20 to 212°F (-29 to 100°C); Relative humidity: 0 to 100% RH.  
**Accuracy:** Air velocity: 100 to 3500 fpm: ±5% of reading ±7 fpm (0.5 to 20 m/s); ±5% of reading ±0.04 m/s; Temperature: ±0.54°F @ 77°F (±0.3°C @ 25°C); Relative humidity: ±2% @ 77°F (25°C) (10 to 90% RH); ±4% (0 to 10% RH and 90 to 100% non-condensing).  
**Resolution:** 1 FPM (0.001 m/s).

**Response Time:** Air velocity and air volume: 1 s; Temperature and relative humidity: 1.5 s.  
**Probe Length:** 8" (203 mm) insertion.  
**Battery Charging Limits:** 32 to 113°F (0 to 45°C).  
**Power Requirements:** 3.7 V YT562447 Lithium ion battery.  
**Maximum Wireless Distance:** 50' (15 m).  
**Handle Enclosure:** Thermoplastic elastomer over polycarbonate.  
**Supplied With:** Wrist strap.  
**Weight:** 13.6 oz (385 g).  
**Agency Approvals:** CE (not while charging), FCC compliant.

## MODEL CHART

Model	Description
VP3	Wireless 100 mm vane thermo-anemometer probe for use with the Model UHH4 or newer universal handheld device, or personal smart device with Mobile Meter® Software.

# DIFFERENTIAL PRESSURE MODULE

Wireless, Measures Differential Pressure, Air Velocity, and Flow

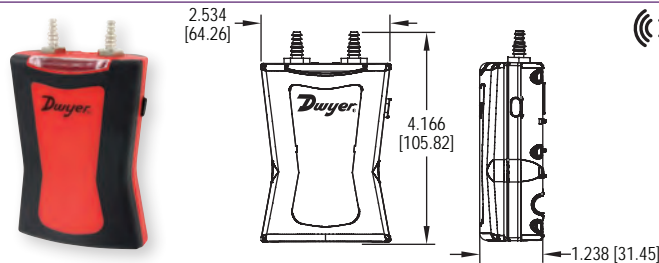

The **Series DP3 Wireless Differential Pressure Module** is a compact, highly accurate, auto-ranging differential pressure module ideal for low flow applications. The Series DP3 is used in conjunction with the Dwyer Mobile Meter® application software to view pressure drop across filters, static pressure in ducts, and velocity pressures from pitot tubes or air flow stations.

### FEATURES/BENEFITS

- Auto ranging technology maintains optimal performance down to 0.1" H<sub>2</sub>O
- LED indicator displays module status, connection, charging and logging to the user
- Over-the-air updates ensure the module has the latest firmware
- Unit can be mounted on both the pitot and velocity grid
- Rechargeable battery allows for a 10 hour battery life
- One button design allows for easy operation and simple logging
- Rugged case allows for a 10' drop without compromising functionality
- Automatically corrects pressure reading depending on the inclination of the module

### APPLICATIONS

- Building commissioning
- Building HVAC test and balance
- Critical environment testing
- Industrial process verification
- Instrumentation validation

USA: California Proposition 65

⚠WARNING: Cancer and Reproductive Harm - www.P65Warnings.ca.gov

### SPECIFICATIONS

**Service:** Non-corrosive dry gases.  
**Wetted Materials:** Zinc plated brass; Silicon.  
**Accuracy:** ±0.5% FS span @ 25°C (includes non linearity, hysteresis, and non repeatability).  
**Pressure Limits:** ±10 in w.c. (±2.5 kPa).  
**Temperature Limits:** Operating: -4 to 140°F (-20 to 60°C); Storage: -40 to 185°F (-40 to 85°C).  
**Power Requirements:** 3.7 V lithium ion battery, user rechargeable.  
**Wireless Distance:** 50' (15 m).  
**Weight:** 3.3 oz (93.55 g).  
**Electrical Connections:** Female mini-USB.  
**Hose Connections:** Two barbed connections for use with 1/8" (3.18 mm) or 3/16" (4.76 mm) ID tubing.  
**Approvals:** CE, FCC.

### MODEL CHART

Model	Range	Maximum Pressure
DP3	±10 in w.c. (±2.5 kPa)	10 psi (68.9 kPa)

### OPTIONS

Model	Description
-NIST	NIST traceable calibration certificate

# MOBILE METER® SOFTWARE TEST INSTRUMENT APP

Works With Most Android® and iOS® Phones/Tablets; Wireless Probes



Touch to access parameters  
Connection status

Select individual probe measurements

The **Mobile Meter® Software Test Instrument App** converts Android® and iOS® based phones and tablets into a multi-function test instrument. Wireless probes connect to the phone or tablet using our mobile gateway, Model UHH-BTG, which utilizes wireless technology from Bluetooth SIG Inc. Parameters from multiple probes can be displayed simultaneously, or a single probes parameters can be displayed as a meter or analog gage.

### FEATURES/BENEFITS

- Available on Android® and iOS® devices
- Data logging feature records measurements from a single probe and can email reports directly from device
- Display multiple parameters in gage or meter display

### APPLICATIONS

- Building balancing
- Building commissioning
- Testing HVAC equipment performance

### SPECIFICATIONS

**Operating Systems:** Android® firmware version 3.X or later, iOS® firmware version 5.X or later.  
**Wireless Protocol:** Conforms to Bluetooth SIG, Inc. low energy wireless technology.  
**Wireless Distance:** 50' (15 m) or greater.  
**Response Time:** 1 s.

Android® is a registered trademark of Google, Inc.  
 iOS® is a registered trademark of Cisco Systems, Inc.

# TRAVERSEIT™ AIR VELOCITY MEASURING SOFTWARE APPLICATION

Includes ISO Standard Calculated Flow, Duct Traverse Procedure, Reporting



The **TraverseIT™ Air Velocity Measuring Software Application** displays air flow measurements from Dwyer's Series WDPM Wireless Differential Pressure Module or Series AP3 Hot Wire Thermo-Anemometer Probe and guides balancers through the duct traverse process using step-by-step instructions. The traverse process is a method for calculating the maximum airflow in a duct. Several readings are taken across a traverse plane which are converted into velocity, and averaged. The TraverseIT™ app calculates air flow using ISO 3966 and 5801 standards, yielding highly accurate flow readings with each traverse. The application comes factory installed on a Dwyer rugged handheld unit that is included with a variety of balancing instruments or it can be downloaded directly from the Google Play™ store.

### APPLICATIONS

- Commissioning, testing, adjusting and balancing volumetric air flow in HVAC systems

### SPECIFICATIONS

**Operating System:** Android™ 4.2.2 (Jellybean or newer).  
**Wireless Protocol:** Bluetooth® wireless technology.  
**Response Time:** 1 s.  
 \*Latest updates to application can be downloaded using the Google Play™ store.

### FEATURES/BENEFITS

- Step-through traverse procedure provides duct visuals for quick and proper setup
- Utilizes ISO Standards to calculate high accurate flow
- Generates and shares duct traverse reports directly from the handheld device

Android® is a registered trademark of Google, Inc.  
 Bluetooth® is a registered trademark of Bluetooth SIG, Inc.  
 Google Play™ is a trademark of Google, Inc.

# WIRELESS HYDRONIC DIFFERENTIAL PRESSURE MANOMETER

Liquid and Gas Pressure Measurement,  $\pm 2\%$  of Reading Accuracy

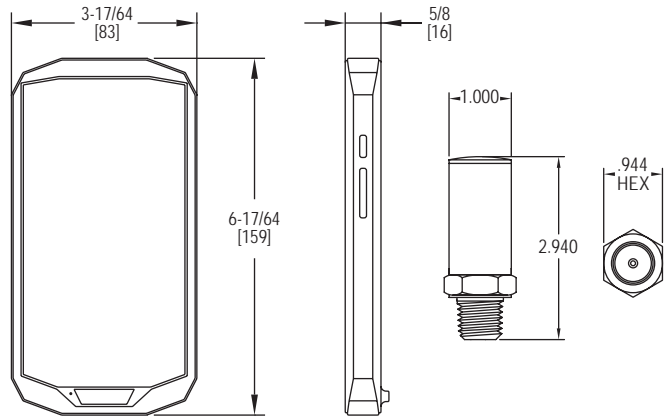

**Series 490W Wireless Hydronic Differential Pressure Manometer** is the most accurate and easy to operate manometer on the market. By using wireless transducers and a versatile handheld, a single operator can monitor and balance a hydronic system in less time than traditional hydronic balancers. The Series 490W utilizes mobile technology to communicate via a Bluetooth connection with the transducers to monitor differential pressure and flow on up to three different valves. Being wireless means there are no hoses to carry, snag on equipment or needing to be drained. The 490W includes the Dwyer Hydronic Application Software that contains valve charts for numerous manufacturers, which converts differential pressure to flow directly on the screen.

## FEATURES/BENEFITS

- Rugged weatherproof handheld housing withstands 1.5 meter drop test
- Wireless measurement of differential pressure, single pressure and air flow
- Share logged data directly from handheld over Wi-Fi, GSM or CDMA networks
- Bluetooth direct wireless communication provides range up to 65 ft (19.8 m)
- The ergonomic design is much lighter and easier to work with, providing greater maneuverability and quick install setup

## APPLICATIONS

- Refrigerant pressure testing
- Hydronic valve balancing
- Measure pressure drop across pumps
- Measure pressure drop across chiller and coils for freeze protection

## SPECIFICATIONS

**Wireless Distance:** Up to 65' (19.8 m).  
**Service:** Compatible gases and liquids.  
**Wetted Materials:** 316 SS, PTFE, brass.  
**Accuracy:** 2% of reading,  $\pm 0.5$  psi.  
**Compensated Temperature Range:** 14 to 140°F (-10 to 60°C).  
**Pressure Hysteresis:**  $\pm 0.25\%$  FS.  
**Pressure Range:** See chart.  
**Process Temperature Limits:** -4 to 185°F (-20 to 85°C).  
**Display:** 5" Gorilla® glass 3, touch screen, 1280x720.  
**Resolution:** 0.01 psi.  
**Power Connections:** Two 1/4" male NPT.  
**Power Requirements:** CR2050 or CR2032 lithium battery, user replaceable.  
**Weight:** 2 lb (907 g).  
**Agency Approvals:** CE, FCC.

## MODEL CHART

Model	English Range	Metric Range	Maximum Pressure	Available Engineering Units
<b>490W-6-HKIT</b>	0 to 50 psi, 0 to 200 psi	0 to 344.7 kPa, 0 to 1379 kPa	100 psi (6.89 bar), 400 psi (27.58 bar)	psi, ft w.c., in w.c., Pa, kPa, hPa, cm w.c., mm w.c.
<b>490W-6-HKIT-NIST</b>	0 to 50 psi, 0 to 200 psi	0 to 344.7 kPa, 0 to 1379 kPa	100 psi (6.89 bar), 400 psi (27.58 bar)	psi, ft w.c., in w.c., Pa, kPa, hPa, cm w.c., mm w.c.

## REPLACEMENT TRANSDUCERS

<b>A-490W-1</b>	0 to 15 psi	1.034 bar	30 psig	psi, ft w.c., in w.c., Pa, kPa, hPa, cm w.c., mm w.c.
<b>A-490W-2</b>	0 to 30 psi	2.069 bar	60 psig	psi, ft w.c., in w.c., Pa, kPa, hPa, cm w.c., mm w.c.
<b>A-490W-3</b>	0 to 50 psi	3.447 bar	100 psig	psi, ft w.c., in w.c., Pa, kPa, hPa, cm w.c., mm w.c.
<b>A-490W-4</b>	0 to 100 psi	6.895 bar	200 psig	psi, ft w.c., in w.c., Pa, kPa, hPa, cm w.c., mm w.c.
<b>A-490W-5</b>	0 to 500 psi	34.47 bar	1000 psig	psi, ft w.c., in w.c., Pa, kPa, hPa, cm w.c., mm w.c.
<b>A-490W-6</b>	0 to 200 psi	13.79 bar	400 psig	psi, ft w.c., in w.c., Pa, kPa, hPa, cm w.c., mm w.c.

## ACCESSORIES

Model	Description
<b>A-HKIT-500</b>	Piercing gage adapter, 1/8" dia x 1-1/2" length (2 per kit)
<b>A-HKIT-500XL</b>	Piercing gage adapter, 1/8" dia x 3" length (2 per kit)
<b>A-HKIT-510</b>	Piercing gage adapter, 1/16" dia x 1-1/2" length (2 per kit)

USA: California Proposition 65  
 ⚠ WARNING: Cancer and Reproductive Harm - www.P65Warnings.ca.gov

Gorilla® is a registered trademark of Corning, Incorporated



# HYDRONIC DIFFERENTIAL PRESSURE METER KIT

Liquid and Gas Pressure Measurement,  $\pm 0.5\%$  FS Accuracy



DEALER DESIGN AWARDS

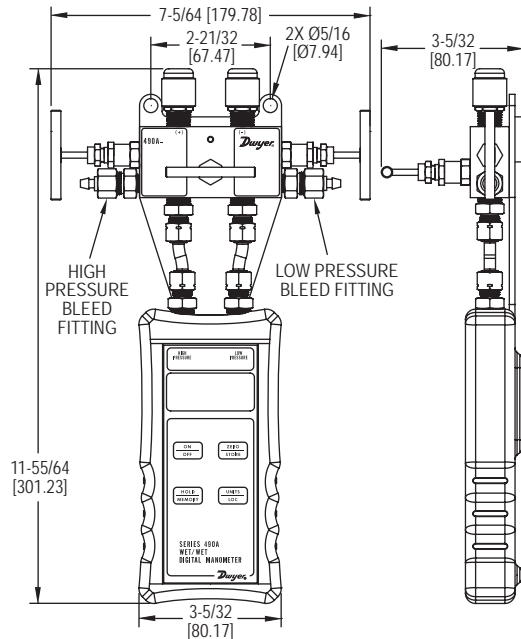

The **Series 490A-HKIT Hydronic Differential Pressure Meter Kit** features the 490A Hydronic Differential Pressure Manometer and all the necessary attachments and accessories to meet all your balancing, measuring, and pressure needs. The manometer featured in this kit is a versatile, handheld, battery operated manometer available in several ranges for positive or positive differential pressure measurement and can tolerate most liquid media compatible with 316L SS.

**FEATURES/BENEFITS**

- Digital dampening for low pressure stability
- Automatic resolution adjustment for finer control
- Hard carrying case protects products
- Stores up to 40 readings for later recall
- Backlight for use in dim areas
- Magnetic back mount for ease of use
- Rubber boot for easy handling and all day comfort

**APPLICATIONS**

- Chiller to coils for freeze protection
- Hydronic valve balancing
- Measure pressure drop across pumps
- Refrigerant pressure testing

**STANDARD KIT INCLUDES:**

- Two (2) 6ft high pressure rated tubing with shut off valves
- One (1) high pressure 3-way valve
- Two (2) controlled bleed valves
- One (1) 8 ft Poly tubing for purges
- One (1) hard traveling lockable case with non-absorbent foam
- One (1) handheld carrying strap
- Two (2) 1/16" x 1-1/2" pressure gage adapters
- Two (2) 1/8" x 3" pressure gage adapters
- Two (2) 1/8" x 1-1/2" pressure gage adapters
- Two (2) Male 90° Flare to 1/4" NPT fittings
- Two (2) Male Flare to 1/4" NPT coupler fittings
- One (1) adjustable 8" wrench
- PTFE Thread Tape
- One (1) magnetic protective rubber boot
- NIST Calibration Certificate Standard



**A-47X-BOOT**  
(manometer not included)

**SPECIFICATIONS**

<b>Service:</b> Compatible gases and liquids.	<b>Storage Temperature Limits:</b> -4 to 176°F (-20 to 80°C).
<b>Wetted Materials:</b> 316L SS, PTFE, Brass, Copper.	<b>Display:</b> 0.42" (10.6 mm) 4 digit LCD.
<b>Accuracy:</b> $\pm 0.5\%$ FS, 60 to 78°F (15.6 to 25.6°C); $\pm 1.5\%$ FS from 32 to 60°F and 78 to 104°F (0 to 15.6°C and 25.6 to 40°C).	<b>Resolution:</b> See chart.
<b>Pressure Hysteresis:</b> $\pm 0.1\%$ FS.	<b>Power Requirements:</b> 9 V alkaline battery, installed non-functional, user replaceable.
<b>Pressure Limits:</b> See chart.	<b>Weight:</b> 3.6 lb.
<b>Electronic Temperature Limits:</b> 32 to 140°F (0 to 60°C).	<b>Process Connections:</b> Two male 45 Flare 1/4".
<b>Process Temperature Limits:</b> -20 to 180°F.	<b>Agency Approvals:</b> CE.

**MODEL CHART**

Model	Range (psi)	Available Pressure Units & Resolution**								Maximum Pressure
		bar	psi	in Hg	kPa	in w.c.	mm Hg	mbar	ft w.c.	
490A-1-HKIT	0 to 15	1.034	15.00	30.54	103.4	415.2	775.7	1034	34.60	30 psig
490A-2-HKIT	0 to 30	2.069	30.00	61.08	206.9	830.4	1551	2069	69.20	60 psig
490A-3-HKIT	0 to 50	3.447	50.00	101.8	344.7	1384	2585	3447	115.3	100 psig
490A-4-HKIT	0 to 100	6.895	100.0	203.6	689.5	2768	5171	6895	230.7	200 psig
490A-5-HKIT	0 to 500	34.47	500.0	1018	3447	9999*	9999*	9999*	1153	1000 psig
490A-6-HKIT	0 to 200	13.79	200.0	407.2	1379	5536	9999*	9999*	461.3	400 psig

\*Digits will display smaller units until all 4 digits are exceeded.  
\*\*Readings less than 10% of range will provide one additional decimal place than shown for higher resolution.

**ACCESSORIES**

Model	Description
A-47X-BOOT	Rubber boot for manometers (manometer no included)
A-HKIT-AFIT	Adapter fitting kit for the 490A-HKIT, includes pairs of SAE 1/4" adapters and elbow fittings
A-HKIT-BFIT	Adapter fitting kit for the 490A-HKIT, includes pair of bleed fitting assemblies
A-HKIT-HOSES	One pair red & blue 60" SAE replacement hoses for the 490A-HKIT, each with integral ball valve
A-HKIT-500	Piercing gage adapter for the 490A-HKIT, 1/8" dia x 1-1/2" length (2 per kit)
A-HKIT-500XL	Piercing gage adapter for the 490A-HKIT, 1/8" dia x 3" length (2 per kit)
A-HKIT-510	Piercing gage adapter for the 490A-HKIT, 1/16" dia x 1-1/2" length (2 per kit)
NIST Calibration	Please contact your regional Dwyer distributor or Dwyer International Sales Office for scheduling your NIST recertification



MODEL 160G

# AVERAGING AIR FLOW GRID

Extends Over 50" to Aid in Air Flow Output Checks

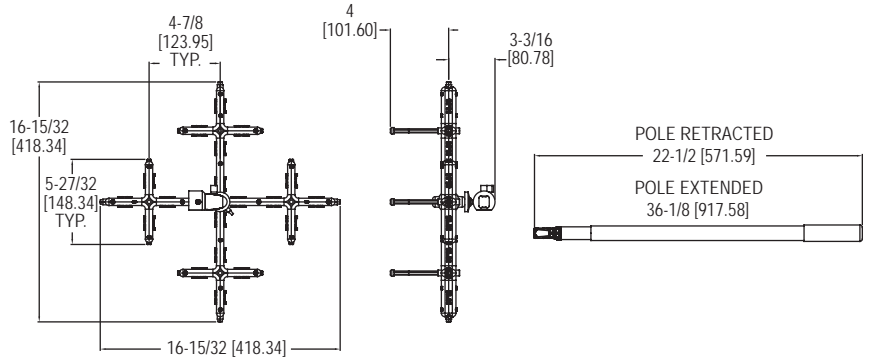

The **Model 160G Averaging Air Flow Grid** utilizes 16 sensing points to provide precision sensing across its 16.5" (41.9 cm) length and width. The ball pivot joint and tightening nut allows the user to position the sensing grid at any angle in any direction for ease of use in hard to reach locations. The included color coded tubing connects to the integral barbed fittings, providing a differential pressure signal to a gage or manometer where the readings can be converted into a velocity or flow reading.

**FEATURES/BENEFITS**

- Maximum reach of approximately 48" (122 cm)
- 16 sensing points provide an accurate average flow

**APPLICATIONS**

- Measure face air velocity on grills, diffusers, registers, exhaust hoods

MODEL CHART	
Model	Description
160G	Averaging air flow grid

**SPECIFICATIONS**

**Service:** Air or compatible gases.  
**Wetted Materials:** Grid: Black polycarbonate; Ball pivot joint: AL, plastic; Handle: Aluminum; Standoffs: Aluminum with rubber bumpers, two sets: 1.25" (31.7 mm) and 2" (50.8 mm), 1/8" ID / 1/4" OD; Tubing: Two 10' (3 m) lengths of silicone rubber.  
**Accuracy:** ±2% FS.

**Temperature Limits:** -40 to 257°F (-40 to 125°C).  
**K Factor:** 0.84.  
**Range:** 1000 to 5000 FPM (5 to 25 m/s).  
**Process Connection:** 1/8 to 1/4" ID tubing.  
**Weight:** 1.75 lb (0.79 kg).  
**Agency Approvals:** RoHS.

ACCESSORIES	
Model	Description
UHH-C2	Protective hard case



UHH-C2

MODEL 485B

# THERMO-HYGROMETER

Measures % RH, Temperature, Dew Point and Wet Bulb

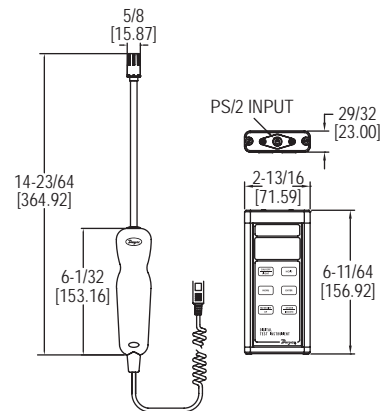

The **Model 485B Thermo-Hygrometer** is a versatile, compact, handheld instrument for measuring percentage of relative humidity and temperature in °F or °C. Dew point and wet bulb temperatures are derived from the relative humidity and temperature measurements and are displayed on the LCD.

**FEATURES/BENEFITS**

- Compatible with Dwyer AP1 thermo-anemometer and VP1 100 mm vane thermo-anemometer probes (sold separately)
- Hold feature to freeze current readings on the display
- Stores up to 99 readings for future evaluation

**APPLICATIONS**

- Building commissioning
- Pulp and paper

MODEL CHART	
Model	Description
485B-1	Digital thermo-hygrometer includes 9V battery, sensing probe, wrist strap, soft carrying case and instructions

OPTIONS	
Use order code:	Description
-NIST	NIST traceable calibration certificate

**SPECIFICATIONS**

**Service:** Humidity, temperature, wet bulb and dew point temperature detection in clean air.  
**Temperature Limits:** Process: -40 to 176°F (-40 to 80°C) Ambient: 5 to 125°F (-15 to 51°C).  
**Range Relative Humidity:** 0 to 100% (non-condensing).  
**Accuracy Relative Humidity:** ±2% FS over 10 to 90% @ 77°F (25°C).  
**Range Temperature:** -20 to 140°F (-28 to 60°C).  
**Accuracy Temperature:** ±0.54°F @ 72°F (±0.3°C @ 25°C).  
**Display:** 4.5 digit LCD.  
**Resolution:** 0.1%, 0.1 °F/°C.  
**Probe Length:** 8" (203 mm) insertion.  
**Power Requirements:** 9 V alkaline battery, included, user replaceable.  
**Weight:** 16 oz (454 g).  
**Agency Approvals:** CE.

ACCESSORIES	
Model	Description
RP1	Thermo-hygrometer % RH and temperature probe with coiled cable
UHH-C1	Soft carrying case
A-47X-BOOT	Protective magnetic rubber boot



# THERMO-ANEMOMETER TEST INSTRUMENT

Measures Air Velocity or Air Volume and Temperature Simultaneously

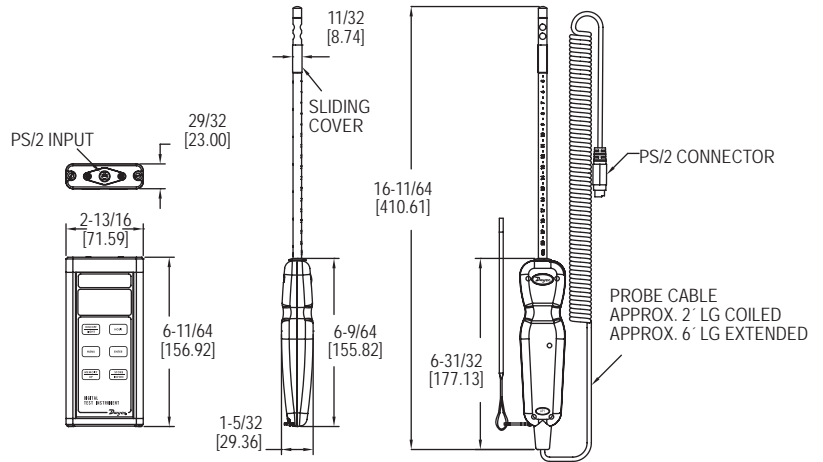

The **Model 471B Thermo-Anemometer Test Instrument** is a versatile dual function unit that quickly and easily measures air velocity or volumetric flow as well as air temperature in imperial or metric units. A stainless steel probe is included, which has a comfortable hand grip and etched insertion depth marks. The extruded aluminum housing fully protects electronics, yet is lightweight and comfortable to hold.

**FEATURES/BENEFITS**

- Compatible with Dwyer RP1 thermo-hygrometer and VP1 100 mm vane thermo-anemometer probes (sold separately)
- High contrast and backlit LCD for visibility in any condition
- Able to store up to 99 readings
- Integral sliding cover protects probe sensors when not in use
- Built-in volumetric air flow calculations

**APPLICATIONS**

- Duct traverses
- HVAC inspections
- Testing and balancing

MODEL CHART	
Model	Description
471B-1	Digital thermo anemometer includes 9V battery, sensing probe, wrist strap, soft carrying case and instructions

ACCESSORIES - CASES	
Model	Description
UHH-C1	Spare soft carrying case
A-160-CASE	Hard carrying case for longer probes (18" to 36")
A-47X-BOOT	Protective magnetic rubber boot

ACCESSORIES - PROBES		
Model	Probe Length	Description
AP1	8"	Thermo anemometer air velocity and temperature probe with coiled cable
AP1-18	18"	Thermo anemometer air velocity and temperature probe with coiled cable
AP1-24	24"	Thermo anemometer air velocity and temperature probe with coiled cable
AP1-36	36"	Thermo anemometer air velocity and temperature probe with coiled cable

**SPECIFICATIONS**

**Service:** Air velocity and temperature of clean, dry air.  
**Temperature Limits:** Process air velocity: -20 to 212°F (-29 to 100°C); Process temperature: -40 to 212°F (-40 to 100°C); Ambient: 5 to 125°F (-15 to 51°C).  
**Display:** 4.5 digit LCD.  
**Resolution:** 0.1%, 0.1°F/°C.  
**Range Air Velocity:** 0 to 6000 FPM (0 to 30 m/s).  
**Air Velocity Accuracy:** ±3% FS within temperature range of 40 to 90°F (4 to 32°C). -TAB option: ±5% of reading, not less than ±1.6 FPM (0.5 m).  
**Range Volumetric Air Flow:** 19,999 in selected flow units.  
**Range Temperature:** -40 to 212°F (-40 to 100°C).  
**Accuracy Temperature:** ±0.5°F (±0.28°C) from 32 to 122°F (0 to 50°C); ±1.5°F (±0.83°C) from -40 to 32°F (-40 to 0°C) & 122 to 212°F (50 to 100°C).  
**Probe Length:** 8" (203 mm) insertion.  
**Cable Length:** 28" (71 cm) retracted, 6 ft (183 cm) extended.  
**Power Requirements:** 9 V alkaline battery, installed non-functional, user replaceable.  
**Weight:** 16 oz (454 g).  
**Agency Approvals:** CE.



OPTIONS	
Model	Description
-NIST	NIST traceable calibration certificate

Thermo-Anemometers

**Dwyer**

MODEL 473B

# 100 MM VANE THERMO-ANEMOMETER TEST INSTRUMENT

Measures Air Velocity or Air Volume, Temperature, and Humidity Simultaneously

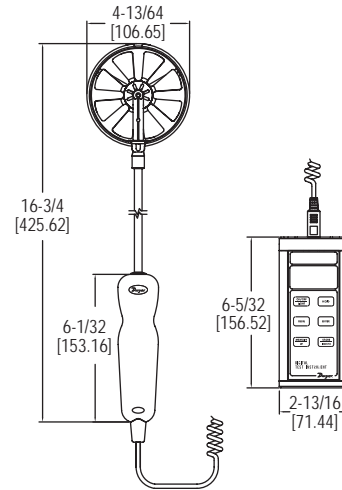

The **Model 473B 100 mm Vane Thermo-Anemometer Test Instrument** is a versatile unit that quickly and easily measures air velocity or volumetric air flow, as well as air temperature and humidity in imperial or metric units. A stainless steel 100 mm vane probe is included, which has a comfortable hand grip. The extruded aluminum housing fully protects electronics, yet is lightweight and comfortable to hold.

**FEATURES/BENEFITS**

- Compatible with Dwyer AP1 thermo-anemometer and RP1 thermo-hygrometer wired probes (sold separately)
- Included 100 mm vane probe is able to measure air velocity, volumetric air flow, temperature, and humidity
- High contrast and backlit LCD for visibility in any condition
- Able to store up to 99 readings for later evaluation

**APPLICATIONS**

- Residential balancing
- HVAC inspections

**MODEL CHART**

Model	Description
473B-1	Vane thermo-anemometer test instrument

**OPTIONS**

To order add suffix:	Description
-COC	Certificate of calibration
-FC	Factory calibration certificate
-NIST	NIST traceable calibration certificate

Example: 473B-1-NIST

**SPECIFICATIONS****Service:** Dry, clean air.**Temperature Limits:** Process: -20 to 212°F (-29 to 100°C); Ambient: 5 to 125°F (-15 to 51°C).**Display:** 4.5 digit backlit display.**Range:** Air velocity: 40 to 5000 FPM (0.2 to 25 m/s); Volumetric air flow: 19,999 in selected flow units; Temperature: -20 to 212°F (-29 to 100°C); Relative humidity: 0 to 100% RH.**Accuracy:** Air velocity:  $\pm 1.5\%$  of reading  $\pm 20$  FPM ( $\pm 0.1$  m/s) [0.25 to 10 m/s];  $\pm 1.5\%$  of reading  $\pm 40$  FPM ( $\pm 0.2$  m/s) [10 to 20 m/s];  $\pm 1.5\%$  of reading  $\pm 60$  FPM ( $\pm 0.3$  m/s) [20 to 25 m/s]; Temperature:  $\pm 0.54^\circ\text{F}$  @  $77^\circ\text{F}$  ( $\pm 0.3^\circ\text{C}$  @  $25^\circ\text{C}$ ); Relative humidity:  $\pm 2\%$  @  $77^\circ\text{F}$  ( $25^\circ\text{C}$ ) [10 to 90% RH];  $\pm 4\%$  [0 to 10, 90 to 100% RH].**Response Time:** Air velocity: 1 s; Volumetric air flow: 1 s; Temperature: 1.5 s; Relative humidity: 1.5 s.**Probe Length:** 8" (203 mm) insertion.**Cable Length:** 28" (71 cm) retracted; 6' (18.3 m) extended.**Vane Material:** Anodized aluminum.**Power Requirements:** 9 V alkaline battery, installed non-functional, user replaceable.**Weight:** 18.4 oz (521 g).**ACCESSORIES**

Model	Description
A-47X-BOOT	Protective magnetic rubber boot
A-VPX-CKIT	Vane hood kit
AP1*	Hot wire thermo-anemometer probe with coiled cable
RP1*	Thermo-hygrometer probe with coiled cable
UHH-C1	Soft carrying case
VP1*	100 mm vane thermo-anemometer probe with coiled cable (replacement)

\*Consult website for more details.

A-47X-BOOT  
(manometer not included)

A-VPX-CKIT



AP1



RP1



UHH-C1



VP1

# HANDHELD DIGITAL MANOMETER

Measures Pressure, Flow and Velocity;  $\pm 0.5\%$  Accuracy

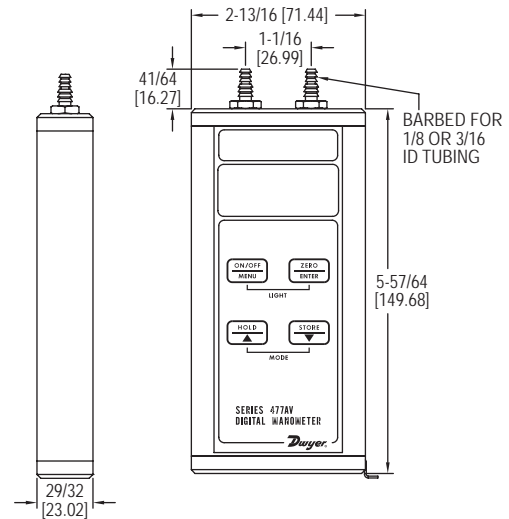

The **Series 477AV Handheld Digital Manometer** is now available with pressure, flow, and velocity measurements along with a number of other convenient features. The built-in air velocity and flow calculations provide accuracy and conserve time and error associated with manual calculations. Also featured on this unit are adjustable zero and span values for calibrating in the field, as well as a damping feature to compensate for the fluctuating of readings.

**FEATURES/BENEFITS**

- Calculates and displays air velocity and volumetric air flow
- Rugged aluminum case protects instrument from damage during transport/use
- 9 selectable English and metric engineering units
- Large, easy to read display with backlight for use in dark areas
- Stores up to 40 readings with minimum, maximum and average statistics

**APPLICATIONS**

- Air flow monitoring
- Duct static pressure

**SPECIFICATIONS**

**Service:** Air and compatible gases.  
**Wetted Materials:** Consult factory.  
**Accuracy:**  $\pm 0.5\%$  FS, 60 to 78°F (15.6 to 25.6°C);  $\pm 1.5\%$  FS from 32 to 60°F and 78 to 104°F (0 to 15.6°C and 25.6 to 40.0°C).  
**Pressure Hysteresis:**  $\pm 0.1\%$  FS.  
**Pressure Limits:** See chart.  
**Temperature Limits:** 0 to 140°F (-17.8 to 60°C).  
**Compensated Temperature Limits:** 32 to 104°F (0 to 40°C).  
**Storage Temperature Limits:** -4 to 176°F (-20 to 80°C).  
**Display:** 0.42" (10.6 mm) 4 digit LCD.  
**Resolution:** See chart.

**Units of Pressure:** in w.c., ft w.c., in Hg, psi, oz/in<sup>2</sup>, mm w.c., cm w.c., mm Hg, mbar, Pa, kPa, hPa.  
**Units of Velocity:** fpm, fps, mph, m/h, m/s, k/h, knot.  
**Units of Flow:** cfm, m<sup>3</sup>/h, m<sup>3</sup>/s.  
**Power Requirements:** 9 V alkaline battery, installed non-functional, user replaceable.  
**Weight:** 10.2 oz (289 g).  
**Process Connections:** Two barbed connections for use with 1/8" (3.18 mm) or 3/16" (4.76 mm) ID tubing. Two compression fittings for use with 1/8" (3.18 mm) ID x 1/4" (6.35 mm) OD tubing for 477AV-7 and 477AV-8 only.  
**Agency Approvals:** CE.

**MODEL CHART**

Model	Pressure Range	Velocity Range		Available Pressure Units												Maximum Pressure
		fpm	m/s	psi	in Hg	kPa	in w.c.	mm Hg	mbar	mm w.c.	Pa	ft w.c.	oz/in <sup>2</sup>	hPa	cm w.c.	
477AV-000	0 to 1.000 in w.c.	4004	20.34	-	0.0736	0.2491	1.000	1.868	2.491	25.40	249.1	0.0833	0.5780	2.491	2.540	5 psig
477AV-00	0 to 4.000 in w.c.	8009	40.69	0.1445	0.2942	0.996	4.000	7.473	9.96	101.6	996	0.3333	2.312	9.964	10.16	5 psig
477AV-0	0 to 10.00 in w.c.	1.266k	64.33	0.3613	0.7355	2.491	10.00	18.68	24.91	254.0	2491	0.8333	5.780	24.91	25.40	5 psig
477AV-1	0 to 20.00 in w.c.	1.791k	90.97	0.7225	1.471	4.982	20.00	37.36	49.82	508.0	4982	1.667	11.56	49.82	50.80	10 psig
477AV-2	0 to 40.00 in w.c.	25.33k	128.7	1.445	2.942	9.96	40.00	74.73	99.6	1016	9964	3.333	23.12	99.64	101.6	10 psig
477AV-3	0 to 200.0 in w.c.	56.63k	287.7	7.225	14.71	49.82	200.0	373.6	498.2	5080	-	16.67	115.6	498.2	508.0	30 psig
477AV-4	0 to 10.00 psi	66.62k	338.4	10.00	20.36	68.95	276.8	517.1	689.5	7031	-	13.07	160.0	689.5	703.1	30 psig
477AV-5	0 to 20.00 psi	94.22k	478.6	20.00	40.72	137.9	553.6	1034	1379	-	-	46.13	320.0	1379	1406	60 psig
477AV-6	0 to 30.00 psi	115.4k	586.2	30.00	61.08	206.9	830.4	1551	2069	-	-	69.20	480.0	2068	2109	60 psig
477AV-7	0 to 100.0 psi	210.7k	1070	100.0	203.6	689.5	2768	5171	6895	-	-	230.7	1600	6895	7031	150 psig
477AV-8	0 to 150.0 psi	258.0k	1311	150.0	305.4	1034	4152	7757	-	-	-	346.0	2400	-	-	200 psig

**OPTIONS**

To order add suffix:	Description
-NIST	NIST traceable calibration certificate
Example: 477AV-1-NIST	

**ACCESSORIES**

Model	Description
A-402A	Carrying case; tough gray nylon pouch protects any Series 477AV Manometer; double zippered for quick and easy access, with a belt loop that snaps closed; 7-1/2"H x 3"W x 2-1/4"D (191 x 76 x 57 mm)
UHH-C1	Soft carrying case
A-47X-BOOT	Protective magnetic rubber boot



A-402A



UHH-C1



A-47X-BOOT  
(manometer not included)

# INTRINSICALLY SAFE HANDHELD DIGITAL MANOMETER

Ranges from 1 in w.c. to 150 psid, ±0.5% Accuracy

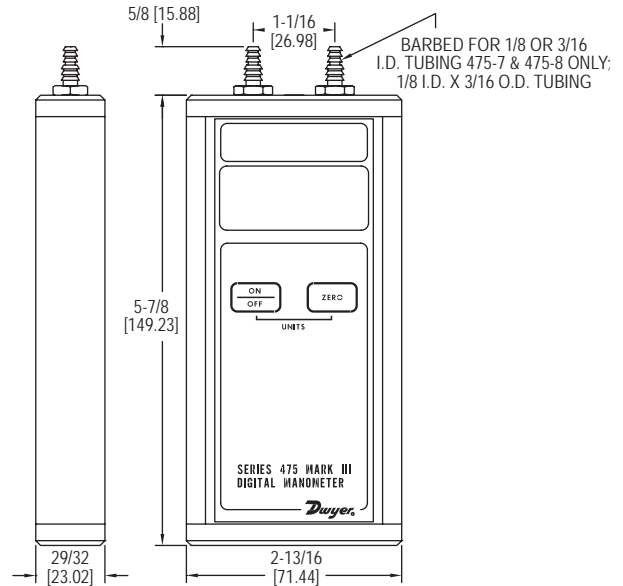

The **Series 475 Intrinsically Safe Handheld Digital Manometer** measures positive, negative, or differential pressures of air and natural gases in ranges from 1 in w.c. (0.249 kPa) to 150 psid (10.34 bar). The dual push pads on the front panel control the on/off, auto zero, and pressure unit selection, allowing for simple operation with no set up needed. When used with a Dwyer® Pitot tube (●), the Series 475 can also be used as an air velocity gage.

**FEATURES/BENEFITS**

- Rugged aluminum case protects instrument from damage during transport/use
- Large, easy to read LCD and simple operation
- FM approved to be intrinsically safe in hazardous locations, Class 1, Div 2, Groups A, B, C, D, T4 Ta = 70°C

**APPLICATIONS**

- Monitoring natural gas pressures on boilers and other combustion equipment
- Air velocity monitoring, when used with a Dwyer® Pitot tube (●) and AV calculator
- Field calibration of other instruments
- Monitoring or troubleshooting HVAC systems

**SPECIFICATIONS**

**Service:** Air and compatible combustible gases.  
**Wetted Materials:** Consult factory.  
**Accuracy:** ±0.5% FS, 60 to 78°F (15.6 to 25.6°C); ±1.5% FS from 32 to 60°F and 78 to 104°F (0 to 15.6°C and 25.6 to 40°C).  
**Pressure Hysteresis:** ±0.1% FS.  
**Pressure Limits:** See chart.  
**Temperature Limits:** 0 to 140°F (-17.8 to 60°C).  
**Compensated Temperature Limits:** 32 to 104°F (0 to 40°C).  
**Storage Temperature Limits:** -4 to 176°F (-20 to 80°C).  
**Display:** 0.42" (10.6 mm) 4 digit LCD.  
**Resolution:** See chart.  
**Power Requirements:** 9 V alkaline battery, installed non-functional, user replaceable.  
**Weight:** 10.8 oz (306 g).  
**Process Connections:** Two barbed connections for use with 1/8" (3.18 mm) or 3/16" (4.76 mm) ID tubing. Two compression fittings for use with 1/8" (3.18 mm) ID x 1/4" (6.35 mm) OD tubing for 475-7 & 475-8 only.  
**Agency Approvals:** CE, FM approved to Class I, Div 2, Groups A, B, C, D, T4 Ta = 70°C.

MODEL CHART			
Model	English Range	Metric Range	Maximum Pressure
475-000-FM	0 to 1.000 in w.c.	.2491 kPa	5 psig
475-00-FM	0 to 4.000 in w.c.	0.996 kPa	5 psig
475-0-FM	0 to 10.00 in w.c.	2.491 kPa	5 psig
475-1-FM	0 to 20.00 in w.c.	4.982 kPa	10 psig
475-2-FM	0 to 40.00 in w.c.	9.96 kPa	10 psig
475-3-FM	0 to 200.0 in w.c.	49.82 kPa	30 psig
475-4-FM	0 to 10.00 psi	.6895 bar	30 psig
475-5-FM	0 to 20.00 psi	1.379 bar	60 psig
475-6-FM	0 to 30.00 psi	2.069 bar	60 psig
475-7-FM	0 to 100.0 psi	6.895 bar	150 psig
475-8-FM	0 to 150.0 psi	10.34 bar	200 psig

ACCESSORIES	
Model	Description
A-402A	Carrying case, tough gray nylon pouch protects any Series 475 manometer, double zippered for quick and easy access, belt loop that snaps closed, 7-1/2"H x 3"W x 2-1/4"D (191 x 76 x 57 mm)
UHH-C1	Soft carrying case
A-47X-BOOT	Protective magnetic rubber boot

OPTIONS	
To order add suffix:	Description
-AV	Air velocity kit, includes the Series 475 manometer, two A-303 static pressure tips two 9' lengths 3/16" ID rubber tubing, no. 166-6-CF pitot tube, A-397 step drill, A-532 air velocity slide chart and instruction bulletin H-11, all packed in a tough, molded plastic carrying case with die cut foam liner.
<b>Examples:</b>	475-1-AV; 475-000-AV
-NIST	NIST traceable calibration certificate
<b>Example:</b>	475-1-NIST



● Pitot tube: See pages 201-234 (Air Quality section)  
 Process Tubing Options: See page 453 (Gage Tubing Accessories)

# SINGLE PRESSURE AND DIFFERENTIAL PRESSURE DIGITAL MANOMETERS

Electronic Zeroing,  $\pm 1.5\%$  Accuracy

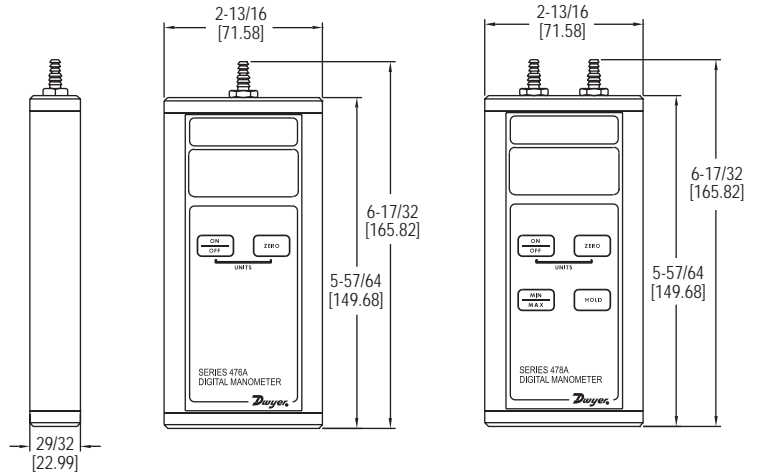

The **Series 476A Single Pressure Digital Manometer** can be used to measure low pressures from -20 to 20 in. w.c. with  $\pm 1.5\%$  FS accuracy. The **Series 478A Differential Pressure Digital Manometer** can be used to measure positive, negative, or differential pressures. Both units are constructed of an extruded aluminum case for exceptional durability.

**FEATURES/BENEFITS**

- $\pm 0.5\%$  FS accuracy
- Rugged extruded aluminum housing
- One button auto-zero function
- Auto power off function to conserve battery life
- Instant selection of up to nine English/metric units

**APPLICATIONS**

- Verify field instrumentation performance
- Adjust fuel mixture on combustion systems

**SPECIFICATIONS**

**Service:** Air and compatible gases.  
**Wetted Materials:** Consult factory.  
**Accuracy:**  $\pm 1.5\%$  FS at 72°F (22.2°C). Includes linearity and repeatability.  
**Pressure Hysteresis:**  $\pm 0.1\%$  FS.  
**Pressure Limits:** 5 psig (.74 bar).  
**Temperature Limits:** 0 to 140°F (-17.8 to 60°C).  
**Compensated Temperature Limits:** 32 to 104°F (0 to 40°C).  
**Thermal Effect:** 0.05% FS/°F.  
**Display:** 4 digit LCD (.425"H x .234"W digits).  
**Power Requirements:** 9 V alkaline battery, installed non-functional, user replaceable.  
**Process Connections:** For use with 3/16" or 1/4" ID tubing.  
**Weight:** 10.8 oz (306 g).  
**Agency Approvals:** CE.

**MODEL CHART**

Model	Range in w.c.	Available Pressure Units								Resolution in w.c.	Maximum Pressure	
		bar	psi	in Hg	kPa	in w.c.	mm Hg	mbar	mm w.c.			Pa
476A-0	-20.0 to 20.0	.0498	0.723	1.471	4.98	20.00	37.4	49.8	508	-	0.02	5 psig
478A-0	-4.00 to 4.00	-	.1445	.294	0.996	4.00	7.47	9.96	101.6	996	0.01	5 psig
478A-1	-60.0 to 60.0	.1495	2.168	4.41	14.95	60.0	112.1	149.5	1524	-	0.1	5 psig

**OPTIONS**

<b>To order add suffix:</b>	<b>Description</b>
-NIST	NIST traceable calibration certificate
<b>Example:</b> 478A-1-NIST	

**ACCESSORIES**

Model	Description
A-402A	Carrying case, tough gray nylon pouch protects any Series 476A/478A manometer, double zippered for quick and easy access, belt loop that snaps closed, 7-1/2"H x 3"W x 2-1/4"D (191 x 76 x 57 mm)
UHH-C1	Soft carrying case
A-47X-BOOT	Protective magnetic rubber boot



# HANDHELD DIGITAL MANOMETER

Precise Air Pressure Measurement,  $\pm 0.1\%$  Accuracy

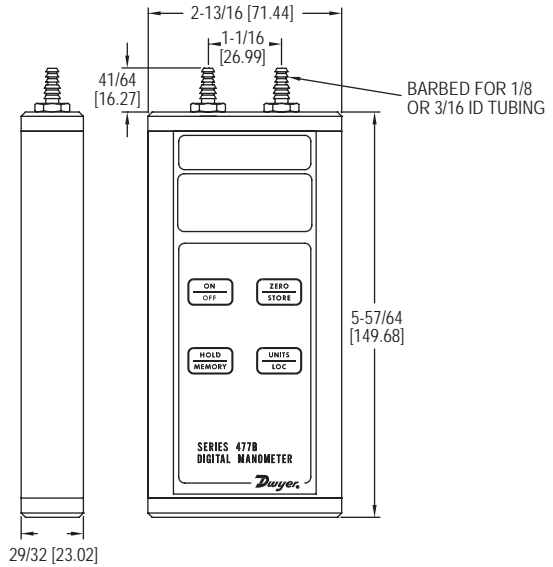

The **Series 477B Handheld Digital Manometer** is a versatile, hand-held, battery operated manometer available in several basic ranges from 0-20 in w.c. up to 100 psi. All models measure either positive, negative or differential pressures with  $\pm 0.10\%$  of full-scale accuracy. You can select from up to seven common English and metric pressure units so conversions are not necessary. A memory function allows storage of up to 40 readings for later recall and a backlight provides auxiliary lighting for hard-to-see locations. Also standard are a hold feature plus both visual and audible overpressure alarms.

**FEATURES/BENEFITS**

- Precise 0.1% FS accuracy provides four times better accuracy than most standard manometer/gages
- Aluminum housing protects instrument against damage
- 40 readings in internal memory reduces time to record data

**APPLICATIONS**

- Lab calibration of other pressure instruments
- Air velocity/air flow measurements in commercial buildings

**SPECIFICATIONS**

**Service:** Air and compatible gases.  
**Wetted Parts:** Consult factory.  
**Accuracy:**  $\pm 0.10\%$  FS from 60 to 78°F (15.6 to 25.6°C);  $\pm 1\%$  FS from 32 to 60 and 78 to 104°F (0 to 15.6 and 25.6 to 40°C).  
**Pressure Hysteresis:**  $\pm 0.1\%$  FS.  
**Pressure Limits:** See chart.  
**Temperature Limits:** 0 to 140°F (-17.8 to 60°C).  
**Storage Temperature Limits:** -4 to 176°F (-20 to 80°C).  
**Display:** 4-digit LCD (.425" H x .234" W digits).  
**Resolution:** See chart.  
**Power Requirements:** 9 V alkaline battery. Battery included but not connected.  
**Connections:** Two barbed connections for use with 1/8" (3.18 mm) or 3/16" (4.76 mm) I.D. tubing for 477B-1, 477B-2, 477B-3, 477B-4 and 477B-5 only. Two compression fittings for use with 1/8" (3.18 mm) I.D. x 1/4" (6.35 mm) O.D. tubing for 477B-6 and 477B-7 only.  
**Weight:** 10.2 oz. (289 g).  
**Agency Approvals:** CE.

MODEL CHART												
Model	Range	Available Pressure Units										Maximum Pressure
		bar	psi	in Hg	kPa	in w.c.	mm Hg	mbar	ft w.c.	mm w.c.	Pa	
477B-1	0 to 20.00 in w.c.	.0498	.7225	1.471	4.982	20.00	37.36	49.82	1.667	508.0	4982	3 psig
477B-2	0 to 40.00 in w.c.	.0996	1.445	2.942	9.96	40.00	74.73	99.6	3.333	1016	9964	3 psig
477B-3	0 to 200.0 in w.c.	.4982	7.225	14.71	49.82	200.0	373.6	498.2	16.67	5080	-	15 psig
477B-4	0 to 10.00 psi	.6895	10.00	20.36	68.95	276.8	517.1	689.5	23.07	7031	-	30 psig
477B-5	0 to 30.00 psi	2.069	30.00	61.08	206.9	830.4	1551	2069	69.20	-	-	60 psig
477B-6	0 to 50.00 psi	3.447	50.00	101.8	344.7	1384	2585	3447	115.3	-	-	100 psig
477B-7	0 to 100.0 psi	6.895	100.0	203.6	689.5	2768	5171	6895	230.7	-	-	200 psig

OPTIONS	
To order add suffix:	Description
-NIST	NIST traceable calibration certificate
Example: 477B-1-NIST	

ACCESSORIES	
Model	Description
A-402A	Carrying case; tough gray nylon pouch protects any Series 477B Manometer; double zippered for quick and easy access, with a belt loop that snaps closed; 7-1/2"H x 3"W x 2-1/4"D (191 x 76 x 57 mm)
UHH-C1	Soft carrying case
A-47X-BOOT	Protective magnetic rubber boot





# AIR VELOCITY KITS

Digital Manometer and Pitot Tube for Balancing System Air Flows



475-XX-FM-AV



475-XXT-FM-AV



477-XXXT-AV

Convenient all-in-one **Series 475-AV & 477-AV Air Velocity Kits** are small, light and easy to use. No set-up or leveling needed. An indispensable test kit for the plant engineer, and HVAC technician that must balance system air flows at start-up.

**FEATURES/BENEFITS**

- Comprehensive kit for HVAC and industrial applications
- Rugged construction for longevity
- Conversion from pressure to air velocity made easy
- Proudly assembled in the USA

**APPLICATIONS**

- Building commissioning
- Building HVAC test and balance
- Critical environment testing
- Industrial process verification
- Instrumentation validation

**MODEL CHART - 475-XX-FM-AV**

Model	Range
475-00-FM-AV	0-4.000 in w.c.
475-0-FM-AV	0-10.00 in w.c.
475-1-FM-AV	0-20.00 in w.c.
475-2-FM-AV	0-40.00 in w.c.

**THE SERIES 475-XX-FM-AV KIT INCLUDES:**

- Series 475 digital manometer (±0.5% FS accuracy and minor divisions to 0.01, large 1/2" LCD readout is easy to see in poorly lighted areas and has "low battery" warning)
- Model 166-6-CF, 6" SS pitot tube with integral compression fitting to hold it securely when taking readings
- Two no. A-303 static pressure tips with magnetic mounting
- Two 9' lengths 3/16" ID rubber tubing
- No. A-397 step drill for 3/16"-1/2" holes in 1/16" increments
- No. A-532 AV slide chart
- 9 V battery
- Fitted polyethylene case

**MODEL CHART - 475-XXT-FM-AV**

Model	Range
475-00T-FM-AV	0-4.000 in w.c.
475-0T-FM-AV	0-10.00 in w.c.
475-1T-FM-AV	0-20.00 in w.c.

**THE SERIES 475-XXT-FM-AV KIT INCLUDES:**

- Series 475 digital manometer (±0.5% FS accuracy and minor divisions to 0.01, large 1/2" LCD readout is easy to see in poorly lighted areas and has "low battery" warning)
- Model 166T, 36" telescoping SS pitot tube, fully adjustable from 11.5" to 36" (29.2 to 91.4 cm)
- Two no. A-303 static pressure tips with magnetic mounting
- Two 4-1/2' L 3/16" ID rubber tubing
- No. A-397 step drill for 3/16"-1/2" holes in 1/16" increments
- No. A-532 AV slide chart
- 9 V alkaline battery
- Fitted polyethylene case

**MODEL CHART - 477AV-XXXT-AV**

Model	Range
477-000T-AV	0-1.000 in w.c.
477-00T-AV	0-4.000 in w.c.
477-0T-AV	0-10.00 in w.c.
477-1T-AV	0-20.00 in w.c.

**THE SERIES 477-XXXT-AV KIT INCLUDES:**

- Series 477AV digital manometer (±0.5% FS accuracy, calculates air velocity or volumetric air flow, stores up to 40 readings in memory, instantly selecting up to nine English/Metric pressure units, large, backlit 0.4" LCD readout, both audible and visual overpressure alarms and a "low battery" warning are standard features)
- Model 166T, 36" telescoping SS pitot tube, fully adjustable from 11.5" to 36" (29.2 to 91.4 cm)
- Two no. A-303 static pressure tips with magnetic mounting
- Two 4-1/2' L 3/16" ID rubber tubing
- No. A-397 step drill for 3/16"-1/2" holes in 1/16" increments
- No. A-532 AV slide chart
- 9 V alkaline battery
- Fitted polyethylene case



SERIES HM35

# PRECISION DIGITAL PRESSURE MANOMETER

Up to 0.05% Accuracy, Graphical Display, Data Logging Capability

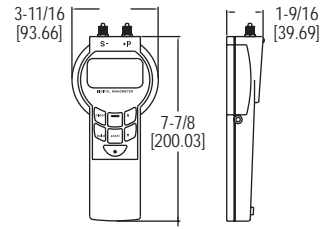

The Series HM35 Precision Digital Pressure Manometer is designed to reliably measure and log absolute pressure, differential pressure, or gage pressure with up to 0.05% accuracy. The data logging function can store up to 10,742 readings and transmit the readings to a PC through an IR serial port. The large display can graphically display trends in the data as well as peaks and valleys.

**FEATURES/BENEFITS**

- Able to record up to 10,742 readings, which can be downloaded to a PC
- Up to 0.05% accuracy for use in critical applications
- Measure absolute, differential, or gage pressure

**APPLICATIONS**

- Calibration facilities
- Laboratories

**MODEL CHART - ERROR LIMIT 0.2% FS FOR GAGE, VACUUM, AND DIFFERENTIAL PRESSURE**

Model	Range	Over Pressure
HM3531DLB300	0 to 10 in w.c. (0-2.5 kPa)	50 in w.c.
HM3531DLC300	0 to 28 in w.c. (0-7 kPa)	140 in w.c.
HM3531DLE300	0 to 80 in w.c. (0-20 kPa)	600 in w.c.
HM3531DLF300	0 to 120 in w.c. (0-30 kPa)	600 in w.c.
HM3531DLG300	0 to 200 in w.c. (0-50 kPa)	58 psi
HM3531DLH300	0 to 14.5 psi (0-100 kPa)	58 psi

**Note:** For higher accuracy models, change the 10th digit from a 3 to a 1 (0.05% FS), 2 (0.1% FS), or 6 (0.1% of reading); higher accuracies are only available on 0 to 28 in of w.c. range or higher.

**Example:** HM3531DLC100 (0 to 28 in w.c. with 0.05% accuracy); consult factory.

**SPECIFICATIONS**

**Service:** Air and compatible gases.  
**Wetted Materials:** 18/8 stainless steel.  
**Accuracy:** (Includes linearity, hysteresis, and repeatability): Depending on model; ±0.20% FS ±1 digit; ±0.10% FS ±1 digit; ±0.05% FS ±1 digit.  
**Temperature Limits:** 32 to 122°F (0 to 50°C).  
**Storage Temperature:** -4 to 140°F (-20 to 60°C).  
**Humidity:** Maximum 95% RH non-condensing.  
**Display:** Graphical back lit LCD. 128 x 64 points.  
**Power Requirements:** (3) 1.5 V AA alkaline batteries, installed functional, user replaceable. Can operate on 6 to 9 VDC external power.  
**Current Consumption:** 25 mA without back lit display, IR, or buzzer.  
**Memory:** 10,742 readings. Recording intervals adjustable from 1 s to 24 hrs or manual.  
**Case Protection:** IP54 (NEMA 3).  
**Weight:** 10.5 oz (300 g).  
**Process Connections:** Hose 4/6 mm or 1/8" NPT.

**ACCESSORIES**

Model	Description
HM28-0	1/8" NPT adapter (1 piece)
HM35-1	Communication software key
HM35-2	Infrared RS-232 serial adapter, required to download stored data to a PC
HM35-3	External power converter with U.S. plug adapter, input 100 to 240 VAC, 50/60 Hz

**OPTIONS**

Use order code:	Description
NISTCAL-MD1	NIST traceable calibration certificate

SERIES HM28

# PRECISION HANDHELD DIGITAL MANOMETER

High Accuracy (0.2%, 0.1% or 0.05%), Differential, Gage or Absolute

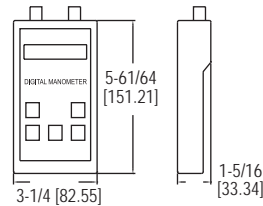

The Series HM28 Precision Handheld Digital Manometer is designed to measure a wide range of pressures with up to 0.05% accuracy. The data logging function can store up to 964 readings and transmit the readings to a PC through an IR serial report. The dual line LCD is able to display a resolution to 0.001 of the selected unit and indicate peaks and valleys.

**FEATURES/BENEFITS**

- Measures differential, gage, or absolute pressure
- Able to record up to 964 readings, which can be downloaded to a PC
- Up to 0.05% accuracy

**APPLICATIONS**

- Calibration facilities
- Laboratories

**MODEL CHART**

Model	Features
<b>Error limit 0.2% FS for gage, underpressure and differential pressure</b>	
HM28D3B10000	0 to 10 in w.c. (2.5 kPa)
HM28D3C10000	0 to 28 in w.c. (7 kPa)
HM28D3F10000	0 to 120 in w.c. (30 kPa)
<b>Error limit 0.05% FS for gage, underpressure and differential pressure</b>	
HM28D3C30000	0 to 28 in w.c. (7 kPa)
HM28D3F30000	0 to 120 in w.c. (30 kPa)
HM28D3K30000	0 to 100 psi (700 kPa)

**For absolute pressure**

HM28A310000	0 to 15.9 psia (0.2% FS (110 kPa abs))
-------------	--

**Note:** Consult factory for 0.10% models.

**SPECIFICATIONS**

**Service:** Air and compatible gases.  
**Wetted Materials:** 18/8 stainless steel.  
**Accuracy:** (Includes linearity, hysteresis, and repeatability): per order code. ±0.20% FS ±1 digit; ±0.10% FS ±1 digit; ±0.05% FS ±1 digit.  
**Temperature Limits:** 23 to 122°F (-5 to 50°C).  
**Storage Temperature:** -4 to 140°F (-20 to 60°C).  
**Humidity:** 30 to 95% rH, non-condensing.  
**Display:** 2 line, 16 character, dot matrix LCD, with switchable display sizes.  
**Power Requirements:** 9 V alkaline battery, installed functional, user replaceable. Can operate from external power supply of 7-14 VDC.  
**Current Consumption:** < 9 mA.  
**Memory:** 964 measured values. Recording intervals adjustable from manual, 1, 5, 10, 20, 30 s, 1, 2, 3, 5, 10, 30, 60 minutes.  
**Case Protection:** IP54 (NEMA 3).  
**Case Dimensions:** 6" x 3.27" x 1.34" (152 x 83 x 34 mm).  
**Weight:** 9.5 oz (270 g).  
**Process Connections:** Hose; 4/6 mm or 1/8" NPT.  
**Maximum Measurement Rates:** Stand alone: 2-1/2 readings/s (0.1% and 0.05% ratings), 5 readings/s (0.2% rating). Output to RS-232: 20 measurements/s (0.2% rating), 10 measurements/s (0.1% and 0.05% ratings).  
**RS-232 Baud Rate:** Adjustable, 1200, 2400, 4800, or 9600 baud.

**ACCESSORIES**

Model	Description
HM28-0	1/8" NPT adapter (1 piece)
HM28-1	Communication software and cable
HM28-2	Universal power adapter

**OPTIONS**

Use order code:	Description
NISTCAL-MD1	NIST traceable calibration certificate

# HYDRONIC DIFFERENTIAL PRESSURE MANOMETER

Liquid and Gas Pressure Measurement,  $\pm 0.5\%$  FS Accuracy

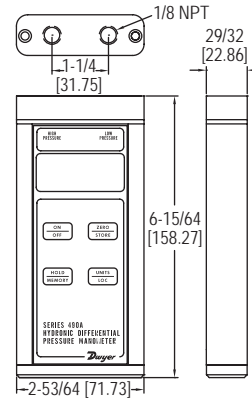

The **Series 490A Hydronic Differential Pressure Manometer** is versatile, hand-held, battery operated manometers available in several basic ranges for positive or positive differential pressure measurement and can tolerate most liquid media compatible with 316L SS.

A new feature added to the Series 490A is a field adjustable damping, which allows the user to choose the level of display averaging rate corresponding to the fluctuation level common in many applications.

### FEATURES/BENEFITS

- Seven user-selectable English and metric units
- Stores up to 40 readings for later recall
- Backlight for use in dim areas
- Digital dampening for low pressure - high resolution logging stability
- Automatic resolution adjustment for finer control

### APPLICATIONS

- Chiller to coils for freeze protection
- Hydronic valve balancing
- Measure pressure drop across pumps
- Refrigerant pressure testing

### SPECIFICATIONS

**Service:** Compatible gases and liquids.  
**Wetted Materials:** Without valve: 316 L SS, -3V option: 316L SS, Buna-N, silicone, grease, PTFE, brass 360, copper, reinforced acetal copolymer.  
**Accuracy:**  $\pm 0.5\%$  FS, 60 to 78°F (15.6 to 25.6°C);  $\pm 1.5\%$  FS from 32 to 60°F and 78 to 104°F (0 to 15.6°C and 25.6 to 40°C).  
**Pressure Hysteresis:**  $\pm 0.1\%$  FS.  
**Pressure Limits:** See chart.  
**Electronic Temperature Limits:** 32 to 140°F (0 to 60°C).  
**Storage Temperature Limits:** -4 to 176°F (-20 to 80°C).  
**Display:** 0.42" (10.6 mm) 4 digit LCD.  
**Resolution:** See chart.  
**Power Requirements:** 9 V alkaline battery, installed non-functional, user replaceable.  
**Weight:** 14.1 oz (400 g).  
**Process Connections:** Two 1/8" (3.18 mm) female NPT.  
**Agency Approvals:** CE.

MODEL CHART										
Model	Range psi	Available Pressure Units & Resolution**								Maximum Pressure
		bar	psi	in Hg	kPa	in w.c.	mm Hg	mbar	ft w.c.	
490A-1	0 to 15.00	1.034	15.00	30.54	103.4	415.2	775.7	1034	34.60	30 psig
490A-2	0 to 30.00	2.069	30.00	61.08	206.9	830.4	1551	2069	69.20	60 psig
490A-3	0 to 50.00	3.447	50.00	101.8	344.7	1384	2585	3447	115.3	100 psig
490A-4	0 to 100.0	6.895	100.0	203.6	689.5	2768	5171	6895	230.7	200 psig
490A-5	0 to 500.0	34.47	500.0	1018	3447	9999*	9999*	9999*	1153	1000 psig
490A-6	0 to 200.0	13.79	200.0	407.2	1379	5536	9999*	9999*	461.3	400 psig

\*Digits will display smaller units until all 4 digits are exceeded.  
 \*\*Readings less than 10% of range will provide one additional decimal place than shown for higher resolution.

OPTIONS	
To order add suffix:	Description
-NIST	Includes NIST Calibration traceable certificate
Example: 490A-1-NIST	
-3V	3-way vent valve with bleed screw rated up to 100 psi
Example: 490A-1-3V	



-3V option  
3-way vent valve

ACCESSORIES	
Model	Description
A-47X-BOOT A-402A	Rubber boot for manometers (manometer no included) Carrying case, tough gray nylon pouch protects any Series 490A manometer, double zippered for quick and easy access, belt loop that snaps closed
A-HKIT-HOSES	One pair red & blue 60" SAE replacement hoses for the 490A-HKIT, each with integral ball valve
A-HKIT-500	Piercing gage adapter for the 490A-HKIT, 1/8" dia x 1-1/2" length (2 per kit)
A-HKIT-500XL	Piercing gage adapter for the 490A-HKIT, 1/8" dia x 3" length (2 per kit)
A-HKIT-510	Piercing gage adapter for the 490A-HKIT, 1/16" dia x 1-1/2" length (2 per kit)
NIST Calibration	Please contact your regional Dwyer distributor or Dwyer International Sales Office for scheduling your NIST recertification



A-47X-BOOT  
(manometer not included)



A-402A

USA: California Proposition 65  
 ⚠ WARNING: Cancer and Reproductive Harm - www.P65Warnings.ca.gov

**Dwyer**

MODEL AQH-20

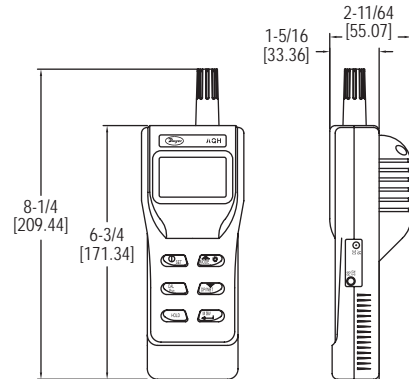
**HANDHELD INDOOR AIR QUALITY METER**Measures CO<sub>2</sub>, Temperature and Humidity

The **Model AQH-20 Handheld Indoor Air Quality Meter** reduces the number of instruments a contractor has to carry by measuring carbon dioxide concentration, air temperature, and humidity percentage in one device. A large backlit LCD shows all three parameters simultaneously. This product offers user selectable engineering units, maximum/minimum/average readings, a hold function, and an audible alarm.

**FEATURES/BENEFITS**

- All-in-one unit for carbon dioxide, temperature, and humidity
- Large backlit LCD for visibility in dark areas
- User configurable alarms for audible indication of hazardous conditions

**APPLICATIONS**

- Building commissioning
- Green house monitoring

MODEL CHART			
Model	CO <sub>2</sub> Range	Humidity Range	Temperature Range
AQH-20	0 to 2000 PPM	0.0 to 99.9%	14 to 140°F (-10 to 60°C)

**SPECIFICATIONS**

**Ranges:** CO<sub>2</sub>: 0 to 2000 PPM; Temperature: 14 to 140°F (-10 to 60°C); Relative humidity: 0.0 to 99.9% RH.  
**Accuracy:** CO<sub>2</sub>: ±30 PPM ±5% of reading; Temperature: ±0.9°F (±0.6°C); Humidity: ±3% RH (10 to 90%), ±5% (0.0 to 9.9% or 90 to 99.9%).  
**Resolution:** CO<sub>2</sub>: 1 PPM; Temperature: 0.1°F (0.1°C); Humidity: 0.1% RH.  
**Response Time:** CO<sub>2</sub>: < 30 s; Temperature: < 2 minutes; Humidity: < 10 minutes.  
**Display:** 4 digits for temperature/CO<sub>2</sub> and 3 digits for humidity.  
**CO<sub>2</sub> Sensor:** Non-dispersive infrared.  
**Temperature Limits:** 32 to 122°F (0 to 50°C).  
**Humidity Limits (Non-Condensing):** 0 to 95% RH.  
**Power Requirements:** (4) 1.5 V AA alkaline batteries, included, user replaceable.  
**Warm Up Time:** 30 s.  
**Weight:** 6.76 oz (200 g).

ACCESSORIES	
Model	Description
TH-CAL	33% and 75% salt bath calibration standards

**MODEL ANE-1****DIFFERENTIAL PRESSURE ANEMOMETER**  
Bi-Directional Anemometer, No Sensing Electronics

Tubing adapter

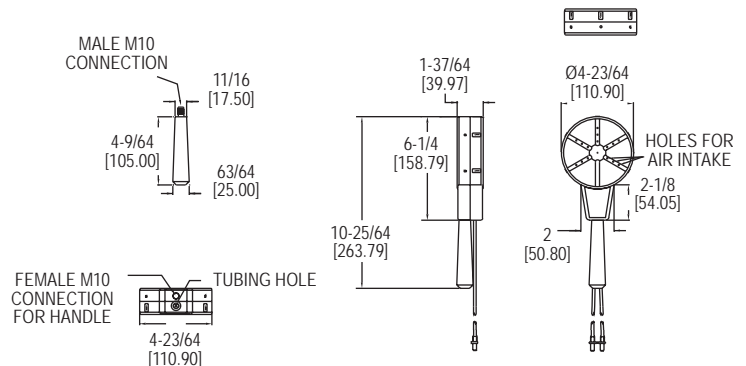

The **Model ANE-1 Differential Pressure Anemometer** is a robust and durable bi-directional anemometer with no moving parts or sensing electronics. Using the installed tubing, the ANE-1 connects easily to any manometer or applicable pressure sensing device and is capable of measuring a wide velocity range. The air velocity range and accuracy is dependent on the installed manometer, and the ANE-1 retains the accuracy as long as it is dust free.

**FEATURES/BENEFITS**

- Wide velocity range dependent on connected manometer
- Includes 5' of blue and 5' of red silicone tubing with a removable adapter sized 2 mm OD to 3/16" OD

**APPLICATIONS**

- Measure face air velocity on grills, diffusers, registers, exhaust hoods

**SPECIFICATIONS**

**Service:** Clean air only.  
**Wetted Materials:** Anemometer: ABS; Tubing: Silicone; Handle: Phenolic.  
**Dimensions:** Tubing: 2 mm ID x 4.5 mm OD; Adapter: 2 mm OD to 3/16" OD connections.  
**Temperature Limits:** 23 to 122°F (-5 to 50°C).  
**K-Factor:** 0.843.  
**Process Connections:** 2 removable 5" (12.7 cm) tubing 3/16" ID.  
**Weight:** 7.7 oz (220 g).

MODEL CHART	
Model	Description
ANE-1	Differential pressure anemometer

# FLEX-TUBE® U-TUBE MANOMETERS

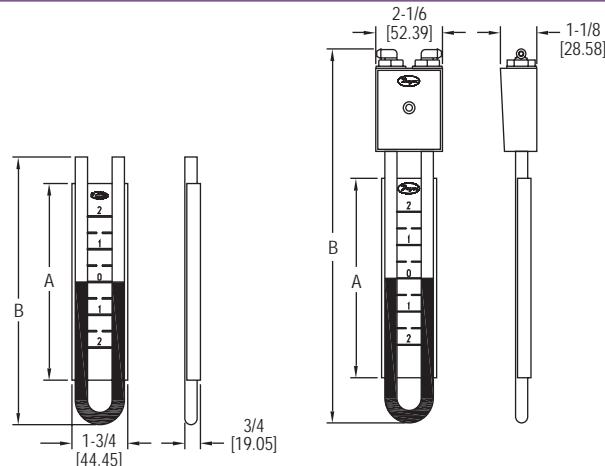

Range		Hg Required to Fill		1221, 2 & 3 Scale Length "A"		1221 & 2 O.A. Length "B"		1223 O.A. Length "B"	
Inches H <sub>2</sub> O	Millimeters H <sub>2</sub> O	Grams	Ounces	W/M	D	W/M	D	W/M	D
8 (4-0-4)	M200 (100-0-100)	178.5	6.3	12-1/4	14	15-1/4	17	18-1/2	19-7/8
12 (6-0-6)	M300 (150-0-150)	225.5	7.9	16-1/4	18-7/8	19-1/4	21-3/4	21-1/8	24-5/8
16 (8-0-8)	M400 (200-0-200)	269	9.5	20-3/8	23-5/8	23-1/4	26-1/2	26-1/8	30-3/8
20 (10-0-10)	-	314.5	11.1	24-1/4	28-1/2	27-1/4	31-1/2	30-1/8	34-3/8
-	M600 (300-0-300)	353.1	12.4	27-7/8	32-7/8	30-3/4	35-3/4	33-5/8	38-5/8
24 (12-0-12)	-	379.7	13.4	28-1/4	33-3/8	31-1/2	36-1/4	33-3/8	39-1/8
36 (18-0-18)	-	491.1	17.3	40-1/4	47-7/8	43-1/4	50-3/4	46-1/8	53-5/8
-	M1000 (500-0-500)	526.6	18.5	43-5/8	52	46-1/2	55	49-3/8	57-7/8

**Note:** Not recommended for vacuum service above 5 in. Hg (68 in w.c.).

The Series 1221/1222/1223 Flex-Tube® U-Tube Manometers combine the inherent accuracy of the "U" Tube with the durability of tough, long-lasting plastic construction. The columns are made of 0.375" O.D. flexible and shatterproof clear butyrate tubing and are backed by a white scale channel to provide maximum color contrast. These manometers are ideal wherever a portable, direct reading manometer is needed.

**FEATURES/BENEFITS**

- Suitable for total pressures up to 100 psi
- High contrast scale for better precision when measuring

**APPLICATIONS**

- Duct static pressure
- Calibration labs
- Filter monitoring

**Series 1221 Flex-Tube® U-Tube Manometer**

Our simplest, lowest cost basic U-gage. A dependable U-tube manometer that withstands hard use and provides accurate, high visibility readings. For use with water, mercury or red gage fluid. For mercury filled manometers, a scale clamp bar, Dwyer® Part No. A-363 (available as an extra for Series 1221 — and standard on Series 1222) is recommended. One pair of carrying plugs and a pair of non-kink vinyl tube connectors are included with each manometer.

**Series 1222 Flex-Tube® U-Tube Manometer**

All the features of the 1221 plus magnetic clips for mounting to any vertical steel surface, and clamp bar to insure against U-tube slipping. (Especially recommended for manometers used with mercury.) Both magnets are easily removed and replaced at the user's convenience.

**Series 1223 Flex-Tube® U-Tube Manometer**

Our finest U-gage — for either portable or stationary use. Safety traps prevent loss of indicating fluid in case of accidental over-pressure. Tubing is permanently bonded to a molded, high impact acrylic plastic top that contains safety traps. Large magnetic clips and clamp bar are provided. Standard type "a" connections include two rapid shut-off type molded nylon tubing connections, two 3-foot lengths of flexible Tygon® plastic tubing, and two 1/8" pipe thread to tube adapters.

MODEL CHART			
Model	Model	Model	Ranges
1221-8-W/M	1222-8-W/M	1223-8-W/M	8 (4-0-4) in w.c.
1221-12-W/M	1222-12-W/M	1223-12-W/M	12 (6-0-6) in w.c.
1221-16-W/M	1222-16-W/M	1223-16-W/M	16 (8-0-8) in w.c.
1221-20-W/M	1222-20-W/M	1223-20-W/M	20 (10-0-10) in w.c.
1221-24-W/M	1222-24-W/M	1223-24-W/M	24 (12-0-12) in w.c.
1221-36-W/M	1222-36-W/M	1223-36-W/M	36 (18-0-18) in w.c.
1221-M200-W/M	1222-M200-W/M	1223-M200-W/M	M200 (100-0-100) mm w.c.
1221-M300-W/M	1222-M300-W/M	1223-M300-W/M	M300 (150-0-150) mm w.c.
1221-M400-W/M	1222-M400-W/M	1223-M400-W/M	M400 (200-0-200) mm w.c.
1221-M600-W/M	1222-M600-W/M	1223-M600-W/M	M600 (300-0-300) mm w.c.
1221-M1000-W/M	1222-M1000-W/M	1223-M1000-W/M	M1000 (500-0-500) mm w.c.

**Note:** To order models with red gage fluid change -W/M to -D.

OPTIONS	
To order add suffix:	Description
-NIST	NIST traceable calibration certificate
<b>Example:</b> 1230-8-W/M-NIST	

ACCESSORIES - STANDARD	
Model	Description
1221	2 plastic carrying plugs; 2 flexible plastic tubing connectors for attachment of 3/16" rubber or plastic tubing without kinking. 1 ounce bottle .826 sp. gr. red gage fluid furnished for "D" style manometers. Fluorescein green dye concentrate furnished with "W/M" style manometers.
1222	2 magnetic mounting clips; tube clamp; 2 plastic carrying plugs and 2 flexible plastic tubing connectors for attachment of 3/16" rubber or plastic tubing without kinking. 1 ounce bottle .826 sp. gr. red gage fluid furnished for "D" style manometers. Fluorescein green dye concentrate furnished with "W/M" style manometers.
1223	Magnetic mounting clips; tube clamp and Type "a" connections consisting of two rapid shut off molded nylon tubing connectors; two 1/8" pipe thread to tube adapters; two 3-foot lengths of Tygon® plastic tubing, 1 ounce bottle .826 sp. gr. red gage fluid is furnished for "D" style manometers; fluorescein green dye concentrate with "W/M" style.

Tygon® is a registered trademark of Saint-Gobain Performance Corporation



SERIES 1211 & MODEL 1212

# SLACK TUBE® MANOMETER



Slack Tube® manometer rolled up for easy handling and storage



1212 gas pressure kit

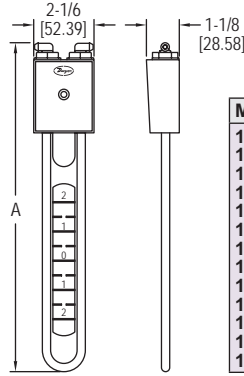

Model	Dimension "A"
1211-8	16-3/4 [425.45]
1211-12	20-3/4 [527.05]
1211-16	24-3/4 [628.65]
1211-24	32-3/4 [831.85]
1211-30	38-3/4 [984.25]
1211-36	44-3/4 [1136.65]
1211-48	56-3/4 [1441.45]
1211-60	68-3/4 [1746.25]
1211-72	80-3/4 [2051.05]
1211-120	128-3/4 [3270.25]
1211-50	28-3/4 [730.25]
1211-100	48-3/4 [1238.25]
1211-200	87-3/4 [2228.85]

The Series 1211 Slack Tube® Manometer is as accurate as the finest laboratory "U" gages, but is designed to roll up compactly for easy carrying. These manometers cover a wide range of pressure readings from 4-0-4 inches up to 60-0-60 inches.

The Model 1212 Gas Pressure Kit includes a 1211-16 Slack Tube® Manometer, carrying case, necessary tubing, and connection fittings for checking gas pressures in virtually all gas appliances.

**FEATURES/BENEFITS**

- Rolls up for easy storage and transport
- Over pressure safety traps to prevent loss of fluid due to over range pressures or surges in pressure

**APPLICATIONS**

- Filter monitoring
- Duct static pressure for setting damper position

MODEL CHART					
Model	Range, In.	Hg Req'd (oz.)	Metric Model	Range, CM	Hg Req'd (oz.)
1211-8	4-0-4	6	1211-50	25-0-25	11
1211-12	6-0-6	7	1211-100	50-0-50	18-1/2
1211-16	8-0-8	9	1211-200	100-0-100	35
1211-24	12-0-12	12-1/2			
1211-30	15-0-15	15			
1211-36	18-0-18	17-1/2			
1211-48	24-0-24	22-1/2			
1211-60	30-0-30	27			
1211-72	36-0-36	32			
1211-120	60-0-60	57			

**INCLUDED WITH THE 1212 KIT**

**Description**

(1) #1211-16 Slack Tube® Manometer, reads pressure to 16" water\*, (1) Carrying case, plastic, 8-1/2" x 7" x 3-1/8", (1) 1 oz. bottle Fluorescein green color concentrate with wetting agent, (2) 1/8" pipe thread rubber tubing adapters, (1) 1/8" to 1/4" pipe thread bushing, (1) 3' L 3/16" rubber tubing, (1) Rubber tubing adapter to fit standard 7/16" dia. spud.

\*Other ranges available.

MODEL CHART	
Model	Description
1212	Gas pressure kit

**ACCESSORIES - STANDARD**

**Description**

Plastic case, magnetic mounting clips, two rapid shutoff type molded nylon rubber tubing connectors and one bottle of fluorescein green color concentrate with wetting agent.

Manometers, Portable

**SERIES 1227**

# DUAL RANGE FLEX-TUBE® U-INCLINED MANOMETERS

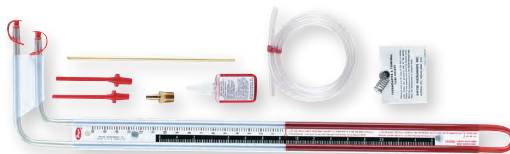

1227 dual range



1227 mounted in incline position

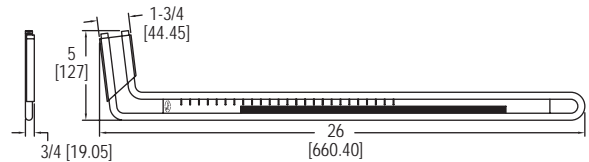

As Vertical U-Tube Manometer	As Inclined Manometer
0-16" water with 1" major divisions, .2" minor divisions	Scale is 17" long, reading .20-0-2.6" water with .02" minor divisions
Model 1227M (metric) is 0-400 mm water column	Model 1227M (metric) is -5 to 0 to 70 mm water column

The Series 1227 Dual Range Flex-Tube® U-Inclined Manometers are versatile, low cost manometers that can be used to read high-range pressure on the right leg or as an inclined manometer to read low-range pressure on the bottom leg. It is made of a sturdy, clear plastic and offers direct readings as a U-tube or an inclined gage. Magnetic clips are attached to the unit to hold it in position on any steel duct surface and instructions are conveniently printed directly on the scale.

**FEATURES/BENEFITS**

- Reads 0 to 16 in w.c. as a U-tube and -0.20 to 0 to 2.6 in w.c. as an inclined gage
- Clear, shatterproof indicating tube provides overpressure protection
- Black markings on a stark white scale for positive definition

**APPLICATIONS**

- Fan status
- Filter monitoring

MODEL CHART	
Model	Description
1227	English units
1227M	Metric units

**ACCESSORIES - STANDARD**

**Description**

Two plastic carrying plugs with retainers for use when manometer is not in service. Two magnetic clips to hold instrument to metal surface. Flexible red vinyl plastic tubing connectors. Brass terminal tube 1/4" diameter x 8" long. One terminal tube holder. Brass adapter, 1/8" pipe thread to plastic tubing. One 4-1/2" length of Tygon® plastic tubing. One 1 ounce bottle .826 sp. gr. red gage fluid. Vinyl carrying case.

USA: California Proposition 65

⚠WARNING: Cancer and Reproductive Harm - www.P65Warnings.ca.gov

Tygon® is a registered trademark of Saint-Gobain Performance Corporation

# GAS PRESSURE MANOMETER

The "Tube in a Tube" Direct Reading Manometer

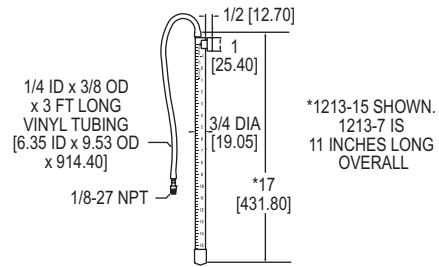

The **Series 1213 Gas Pressure Manometer** provides visual indication of pressure of natural gas up to 15 in w.c. Tap water is used as the sensing media and a magnetic clip provides temporary or permanent mounting. The 1213 is made of a durable plastic for years of trouble-free service, and includes 3' of vinyl tubing and 1/8" nylon male NPT to barb fitting.

**FEATURES/BENEFITS**

- Used to monitor any compatible gas up to 15 in w.c.
- Durable plastic housing for long term use
- Economically priced

**APPLICATIONS**

- Combustion supply gas monitoring

**SPECIFICATIONS**

**Temperature Limit:** 140°F (60°C) maximum.  
**Pressure Limits:** 15 in w.c. (381 mm).  
**Piping Connections:** 1/8" male NPT connector provided.  
**Wetted Materials:** Vinyl, PVC and nylon.  
**Weight:** 5 oz (142 g).  
**Agency Approvals:** Meets the technical requirements of EU Directive 2011/65/EU (RoHS II).

**MODEL CHART**

Model	Length (mm)
1213-15	7" (177.8)

**SERIES MARK II**

# MOLDED PLASTIC AIR VELOCITY METERS

Low in Cost, Direct Reading Scales Offer 3% Accuracy, For Portable or Stationary Applications



27

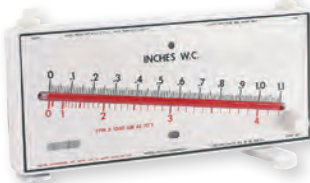

40-AV – Shown with standard swing-out stand and leveling screw installed.

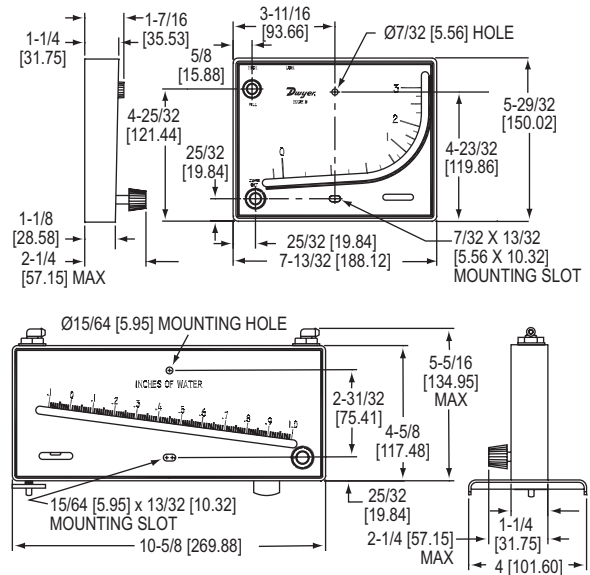

The **Series Mark II Molded Plastic Air Velocity Meters** offer the accuracy and durability of our Mark II manometers with direct air velocity readings. They are designed to be used with Dwyer's Series 160 line of Pitot tubes (not included).

**FEATURES/BENEFITS**

- Thick white styrene-acrylonitrile housing is virtually indestructible
- Moderate overpressures are accommodated by an overflow tank (Model 25) or float operated overflow traps (Model 40)
- Able to be mounted on any vertical surface

**APPLICATIONS**

- Measure air velocity in ducts

**MODEL CHART**

Model	Range
Mark II 27	0 to 7000 FPM
Mark II 28	0 to 10500 FPM
Mark II 40-250 Pa-AV	0 to 21 MPS

**Note:** Pitot tube not included with models above.

**ACCESSORIES**

Model	Description
A-612	Portable stand (for models 27, 28)

**OEM SPECIALS**

All models of the Dwyer® Mark II molded plastic air velocity meters can be supplied with your logo or special scale in OEM quantities. Consult factory for details. See also our Digital Manometers and Pitot tubes.

**Dwyer**  
SERIES 400

## AIR VELOCITY METER

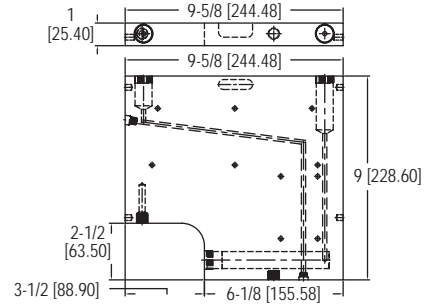

The **Series 400 Air Velocity Meter** offers the convenience of a dual purpose instrument with high accuracy and easy-to-read scales. It can be used to balance air conditioning systems, measure pressure drop across filters, and test fan and blower discharge and inlet pressures. Series 400 kits include a manometer, Pitot tube, necessary tubing and connectors, red gage fluid, and carrying case.

### FEATURES/BENEFITS

- Red figures display velocity in FPM and black figures display air pressure in inch w.c.
- No conversion tables needed for air at standard conditions
- Available with Pitot tubes and carrying case

### APPLICATIONS

- Air balancing
- Building commissioning

### MODEL CHART - WITH COMBINATION INCLINED/VERTICAL SCALES\*

Model	Range in w.c.	Velocity FPM	Minor Div.; Range in w.c.		Pitot Tube
			Inclined	Vertical	
<b>400-10-Kit</b>	0 to 10	400 to 12600	.01, 0 to 1.0	.10, 1-10	18 in
<b>400-10-Gage</b>	0 to 10	400 to 12600	.01, 0 to 1.0	.10, 1-10	None

\*Rated for total pressures to 100 psig (6.89 bar); temperatures to 150°F (65°C)



### Complete kit, Model 400-10

Size\*\*: 11-1/2"H x 20-1/4"W x 1-1/2"D  
Weight: Only 13-1/4 lb with equipment

\*\*Contact factory for extra long steel cases for use with longer Pitot tubes

## MODEL 460

## AIR METER/DRAFT GAGE

A Low-Cost, Direct Reading Instrument Used for Air Velocity and Static Pressure Tests



Furnace draft



Grille velocities

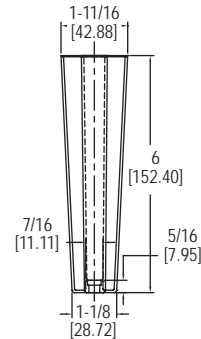

The **Model 460 Air Meter/Draft Gage** is popular for servicing HVAC equipment because of its consistent, accurate results. The direct reading velocity and static pressure scales show supply and return grille velocities, furnace draft, and pressure drop across filters. The 460 is made of a rugged plastic for daily use.

### FEATURES/BENEFITS

- High and low range velocity in one unit
- Simple and quick operation with highly accurate results
- Compact housing for easy portability

### APPLICATIONS

- Measuring grille velocities, furnace draft, and pressure drop across filters

### ACCESSORIES

Model	Description
<b>A-378</b>	Tube of 3 replacement floats
<b>A-379</b>	Supply grille probe
<b>A-380</b>	Return grille probe
<b>A-381</b>	Cleaning kit including 1 anti-static chemically treated pipe stem cleaner and nylon high range orifice cleaner

### MODEL CHART

Model	Description
<b>460</b>	Air meter, complete kit



### Complete pocket-size kit

Includes air meter, return and supply grille probes, angle connector, cleaning materials, instruction card, air velocity calculator and carrying case.



# STAINLESS STEEL PITOT TUBE

## ASME Design Meets AMCA and ASHRAE Codes

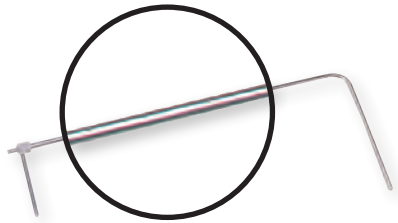

Standard Model 160 pitot tube

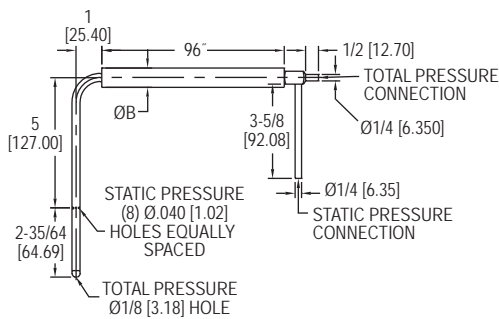

160  
96" and longer with stiffener

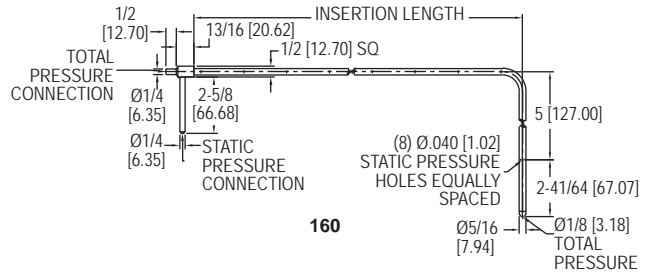

160

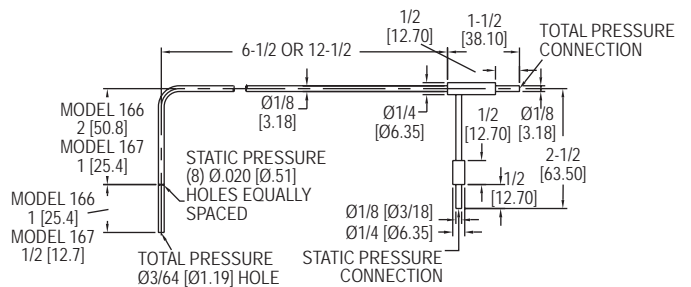

166/167

The **Series 160 Stainless Steel Pitot Tube** is constructed from corrosion resistant stainless steel with permanently etched insertion depth graduations for a lifetime of service. The static pressure port is parallel to the sensing tube to allow quick, easy alignment of the tube with air flow. A universal model fits the user supplied 3/4" schedule 40 pipe in any length.

### FEATURES/BENEFITS

- Low sensitivity to misalignment up to 15 degrees
- No calibration needed due to ASHRAE tip design
- Silver soldered connections for leak-proof operation
- 5/16" models rated to 1500°F (815.5°C)

### APPLICATIONS

- Monitor or control air velocity or air flow when combined with differential pressure gage, switch, or transmitter

### ACCESSORIES

Model	Description
A-156	Flange mounting plate 1/2" female NPT
A-158	Split flange mounting. Can be added to any Dwyer® No. 160 standard pitot tube. Cadmium plated steel. Gasket is pattern for mounting holes. Secure flange loosely to tube, adjust tube depth and tighten screws. Gasket of 1/16" Neoprene fits tightly around tube and against duct for leak-proof seal. Nuts, washers included.
A-159	Mounting gland. Versatile adapter slips on any Series 160, 5/16" standard pitot tube made after Dec. 1990. Two-part stainless steel fitting slides over tube and provides permanent, secure mounting. Where duct interior is accessible, use the washers and jam nut supplied. For blind applications or in thicker materials, use model A-156 flange mounting plate. Once tube is adjusted to proper depth and angle, tighten smaller hex bushing to lock position. Graphite bushing inside assures leak-proof seal even at higher temperatures. TFE bushing also available. <b>Note:</b> For full insertion with this fitting, order next longer pitot tube. A-159 mounting gland is used for both duct mounting and flange mounting.
A-160-CASE A-397	Carrying case for pitot tubes up to 48" Step drill. For fast, convenient installation of pitot tubes in sheet metal ducts. No center punch needed; automatic de-burring. Drills six sizes from 3/16"-1/2" in 1/16" increments.

MODEL CHART			
Standard 5/16" Diameter Model	Insertion Length	Longer Length with Stiffener Model	Insertion Length
160-8	8-5/8"	160-96	96"
160-12	12-5/8"	<b>Pocket Size 1/8" Diameter Model</b>	<b>Insertion Length</b>
160-18	18-5/8"	166-6	6"
160-24	24-5/8"	166-12	12"
160-36	36-5/8"	167-6	6"
160-48	48-5/8"	167-12	12"
160-60	60-5/8"		
Model	Description		
160-KIT	Kit containing 160-18, 160-24, 160-36, 160-48, and carrying case		

### OPTIONS

To order add suffix:	Description
-CF	1/8" male NPT compression fitting, mounting option for Series 166/167

Example: 166-6-CF

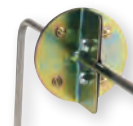

A-158



A-159



To flange mount, the A-159 must be used with the A-156 flange mounting plate.



A-160-CASE



A-397



MODEL 160F

# STRAIGHT STAINLESS STEEL PITOT TUBE

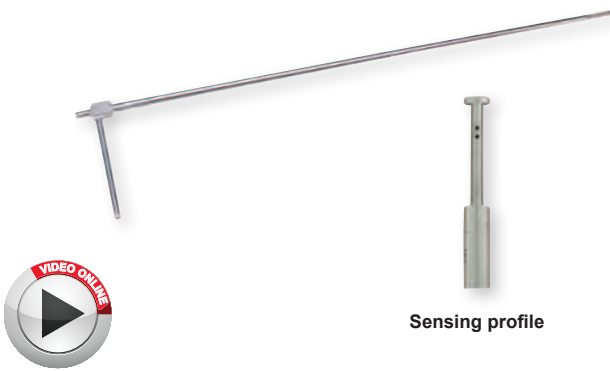

Sensing profile

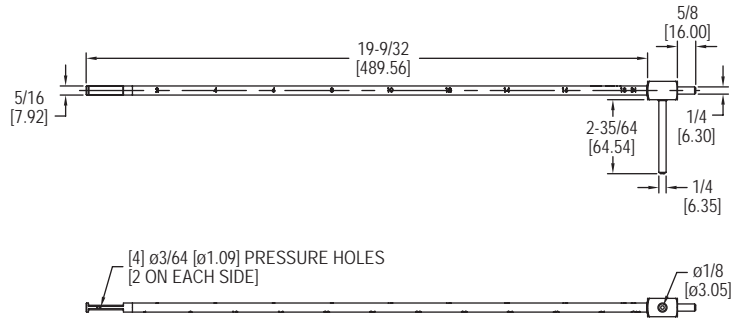

The **Series 160F Straight Stainless Steel Pitot Tube** is constructed from corrosion resistant stainless steel with permanently etched insertion depth graduations for a lifetime of service. The static pressure port is parallel to the sensing tube to allow quick, easy alignment of the tube with air flow. The straight design allows for easy insertion into ducts through grills and pressure taps, as well as aids in positioning in hard to reach locations where a hook style Pitot tube may not allow access.

**FEATURES/BENEFITS**

- Straight design allows for easy insertion into ducts
- Permanent stamped insertion depth graduations facilitate accurate positioning
- Alignment indicator helps keep tip parallel to flow

**APPLICATIONS**

- Monitor or control air velocity or air flow when combined with differential pressure gage, switch, or transmitter where hook style Pitot tubes don't allow access

MODEL CHART			
Model	Probe Length	Model	Description
160F	18" (457.2 mm)	160F-KIT	Kit containing 160-18, 160-24, 160-36, 160-48, and carrying case
160F-24	24" (609.6 mm)		
160F-36	36" (914.4 mm)		
160F-48	48" (1219.2 mm)		
160F-60	60" (1524 mm)		

SPECIFICATIONS	
<b>Wetted Material:</b>	304 SS.
<b>Accuracy:</b>	±2% FS, 0 to 9000 FPM (45 M/s).
<b>K-Factor:</b>	0.81.
<b>Temperature Limit:</b>	1500°F (815°C).
<b>Insertion Length:</b>	18" (44 cm).
<b>Process Connections:</b>	1/4" OD.
<b>Weight:</b>	4.3 oz (122 g).
<b>Agency Approvals:</b>	Meets the technical requirements of EU Directive 2011/65/EU (RoHS II).

ACCESSORIES	
Model	Description
A-156	Flange mounting plate 1/2" female NPT
A-158	Split flange
A-159	Mounting gland
A-160-CASE	Carrying case for pitot tubes up to 48"
A-397	Step drill

MODEL 160E

# ELLIPSOIDAL TIP PITOT TUBE

Designed to Meet ISO Standard 3966

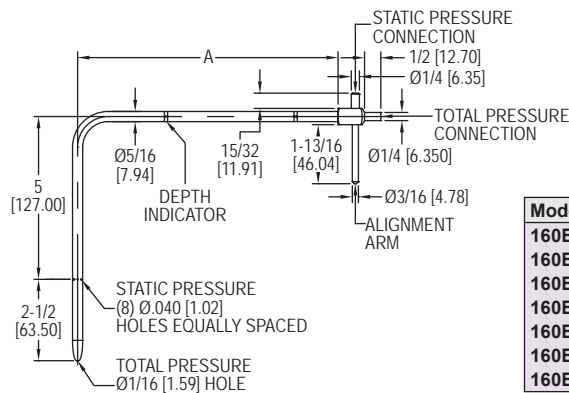

Model	Dim A
160E-00	7-7/8 [200.03]
160E-01	11-7/8 [301.63]
160E-02	18-7/8 [479.43]
160E-03	31-1/2 [800.10]
160E-04	39-1/2 [1003.30]
160E-05	48 [1219.20]
160E-06	59-7/8 [1520.83]

The **Series 160E Ellipsoidal Tip Pitot Tube** uses a precision crafted tip configuration, which allows air to pass smoothly with minimum turbulence for consistent, reliable readings. Sliding depth indicators grip firmly to ensure uniform insertion when measuring traverses across ducts. Total and static pressure taps are 1/4" (6 mm) and are permanently silver soldered to the connection block, making them leak-proof and durable.

**FEATURES/BENEFITS**

- Designed to meet ISO standard 3966 commonly required in UK and Europe
- Ellipsoidal tip design for improved accuracy
- 304 SS construction adds strength and resists corrosion
- Adjustable depth indicators for fast, consistent traverses
- Alignment indicator helps keep tip parallel to flow

**APPLICATIONS**

- Monitor or control air velocity or air flow when combined with differential pressure gage, switch, or transmitter

MODEL CHART	
Model	Insertion in Meters
160E-00	0.2
160E-01	0.3
160E-02	0.48
160E-03	0.8
160E-04	1.0
160E-05	1.22
160E-06	1.52

ACCESSORIES	
Model	Description
A-160-CASE	Carrying case for pitot tubes up to 1.22 m



Handy A-532 slide chart speeds air velocity calculations. All plastic, stays clean for years. Included with each pitot tube.

# "S" TYPE STAINLESS STEEL PITOT TUBES

Large, Open Tip Design Resists Fouling; Optional Permanent Mount Models

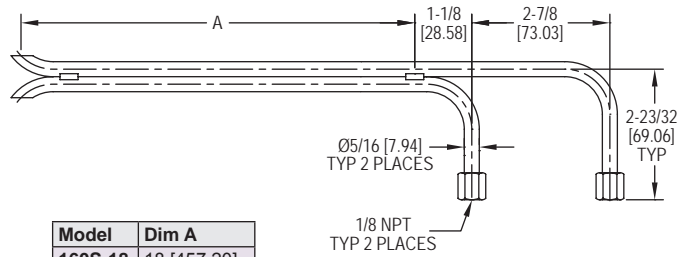
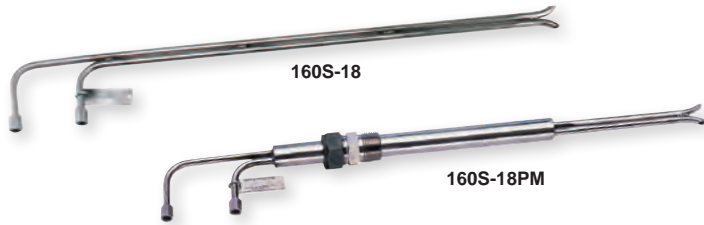

Model	Dim A
160S-18	18 [457.20]
160S-24	24 [609.60]
160S-36	36 [914.40]
160S-48	48 [1219.20]
160S-60	60 [1524.00]

The **Series 160S "S" Type Stainless Steel Pitot Tubes** are designed specifically for flow measurement of dirty, particulate laden air or gas streams typical in smoke stack and other environmental testing. Total and static pressure tubes are precisely aligned and welded together every 6 inches for maximum accuracy, strength, and long term durability. Permanent mount (PM) models include a 1" welded stainless steel sleeve and adjustable compression fitting with 1" MNPT mounting threads.

#### FEATURES/BENEFITS

- Large 5/16" stainless steel tubing resists plugging under harsh conditions
- 1/8" FNPT connections are permanently welded to unit
- Able to be used in up to 1500°F (815.5°C) and 100 psig (6.89 bar)

#### APPLICATIONS

- Monitor or control air velocity or air flow in particulate laden air streams

MODEL CHART			
Model	Insertion in Inches	Perm. Mtg. Model	Insertion in Inches
160S-18	18	160S-18PM	18
160S-24	24	160S-24PM	24
160S-36	36	160S-36PM	36
160S-48	48		
160S-60	60		
160S-72	72		

**Note:** Permanent Mounting (PM) models include 1 inch dia. welded stainless steel sleeve and adjustable compression fitting with 1 inch male NPT mounting threads. Adjust depth, lock in place.

ACCESSORIES	
Model	Description
A-160-CASE	Carrying case for pitot tubes up to 48"

## MODEL 166T

# TELESCOPING STAINLESS STEEL PITOT TUBE

Adjustable Design Extends Insertion Length to 36 Inches

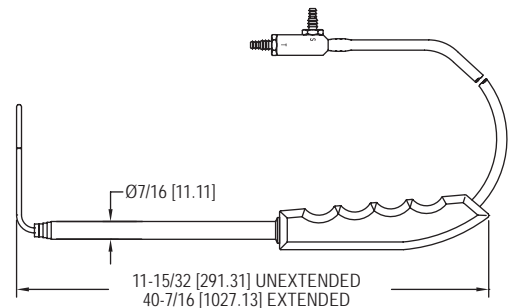

The **Model 166T Telescoping Stainless Steel Pitot Tube** is a unique air flow sensor which can quickly and easily be adjusted for any duct insertion length from 11.5 to 36 inches (29.2 to 91.4 cm), allowing it to replace up to 5 conventional fixed length Pitot tubes. The telescoping sections lock in place as they are extended, which enables the use of the handheld grip to gauge proper alignment of the tip with the airstream. For even greater convenience, it is securely protected by a custom fitted polyethylene carrying case.

#### FEATURES/BENEFITS

- Adjustable length can replace up to 5 fixed length Pitot tubes
- Stainless steel construction resists corrosion
- 1.8" diameter hemispherical tip has 1.0 flow coefficient

#### APPLICATIONS

- Monitor or control air velocity or air flow when combined with differential pressure gage, switch, or transmitter where varying lengths are needed

MODEL CHART	
Model	Description
166T	Telescoping pitot tube

**Dwyer**  
SERIES WIND METER

# PORTABLE WIND METER



Hold this way  
for low scale reading



For high scale reading,  
finger covers hole

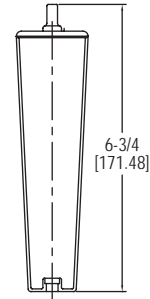
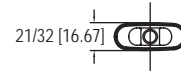

Dimensions: 5/8" W X 6-3/4" H X 17/32" D

The **Portable Series Wind Meter** is used to indicate wind speed and is ideal for yachtsmen, outdoors-men, and farmers. By holding the meter at eye level with the back of the unit to the wind, the white ball in the tube indicates wind speed. The meter has two scales for maximum accuracy.

**FEATURES/BENEFITS**

- Direct reading requires no calculations
- Dual scales to fit any requirement

**APPLICATIONS**

- Fishing, hunting, golf

MODEL CHART	
Model	Scale
Wind Meter-MPH	mph
Wind Meter-KNOT	knots
Wind Meter-KPH	kph
Wind Meter-MPS	m/s

ACCESSORIES	
Model	Description
A-376	Replacement floats for windmeter, tube of 3

**MODEL MW-1**

# POCKET WIND METER

Measures Wind Speed and Temperature, Wide Range

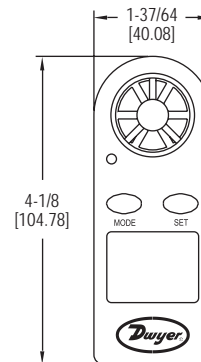

The **Model MW-1 Pocket Wind Meter** measures wind speed and temperature via the integral vane and thermo-anemometer sensor. Users can view readings on the four-digit LCD with wind speed bar graph and select units for air velocity and temperature. The MW-1 also features automatic shut-off, detailed instruction manual, and protective plastic water resistant housing that floats.

**FEATURES/BENEFITS**

- User selectable units to fit any requirement
- Auto shut-off to conserve battery life
- Water resistant plastic housing floats

**APPLICATIONS**

- Balancing applications
- Energy audits
- HVAC inspection

MODEL CHART	
Model	Description
MW-1	Hand-held, mini-vane thermo-anemometer

SPECIFICATIONS	
<b>Air Velocity Range:</b>	0 to 30 m/s, 0 to 5860 ft/min, 0 to 90 km/h, 0 to 65 mph, 0 to 55 knots.
<b>Temperature/Wind-Chill Ranges:</b>	14 to 113°F (-10 to 45°C).
<b>Temperature Resolution:</b>	0.36°F (0.2°C).
<b>Accuracy:</b>	Wind speed: ±5% of reading. Temperature: ±3.6°F (±2°C).
<b>Resolution:</b>	0.1 m/s, 19 ft/min, 0.3 km/h, 0.2 mph, 0.2 knots.
<b>Sample Time:</b>	1 reading per second.
<b>Water-Resistant:</b>	Up to 3' (1 m).
<b>Power Requirements:</b>	3 V CR2032 or BR1225 lithium metal battery, installed functional, user replaceable.
<b>Auto-Off:</b>	14 minutes after last key is pressed.
<b>Impeller:</b>	Plastic, replaceable.
<b>Case:</b>	Plastic.
<b>Display:</b>	2.32 x 2" (59 x 51 mm).
<b>Weight:</b>	1.84 oz (52.1 g).
<b>Agency Approvals:</b>	CE.

ACCESSORIES	
Model	Description
A-166	Replacement vane for MW-1

# VANEOMETER™ SWING VANE ANEMOMETER

Use This Sensitive Dwyer Unit to Measure Low Air Velocities — at Low Cost



Use a Vaneometer™ swing vane anemometer to measure velocity of air flow into laboratory fume hoods and at paint spray booths to determine when to change filters. Or wherever needed to meet OSHA standards of ventilation for smoke, dust or fume removal.

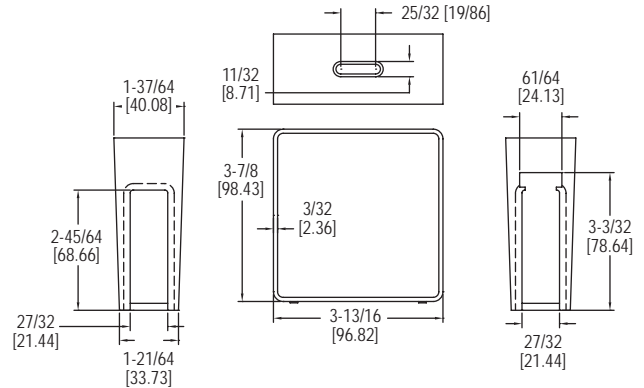

The **Model 480 Vaneometer™ Swing Vane Anemometer** is a durable, economically priced instrument specifically designed to simplify the measurement of low air velocities. It is accurate to ±5% of full-scale to 100 FPM and ±10% from 100 FPM to the top of scale. It has a spirit level to ensure accurate readings and the large scales are easy to read and visible from both sides.

MODEL CHART	
Model	Description
480	25 to 400 FPM
M480	0 to 2.0 m/s

#### FEATURES/BENEFITS

- Small size and weight for easy portability
- Easy to clean ABS plastic housing

#### APPLICATIONS

- Measure air flow into laboratory fume hoods

ACCESSORIES	
Model	Description
A-390	Extra vanes, pkg. of 2

## SERIES MARK II

# WIND SPEED INDICATOR



Includes ABS plastic vane, 50' tubing, mounting hardware and gage fluid.

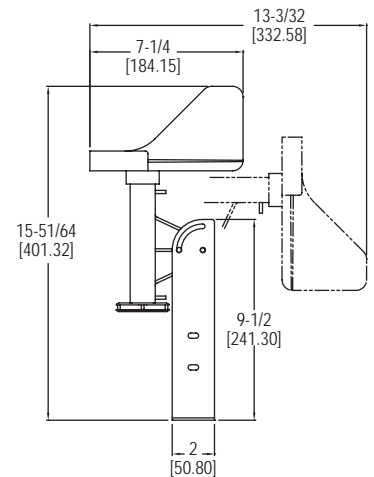
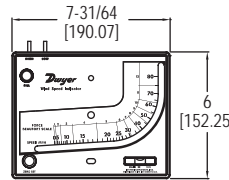

The **Series Mark II Wind Speed Indicator** indicates wind speed directly on the liquid filled scale reading in both miles per hour (0-80) and Beaufort scale (1-12). A metric model is also available, which reads the same as above, but reading 0-130 kilometers per hour. The Mark II Wind Speed Indicator is an accurate, economically priced option for measuring wind speed.

MODEL CHART	
Model	Scale
Mark II WSI	mph
Mark II WSI Metric	kph

#### FEATURES/BENEFITS

- Durable molded white instrument with gold scale
- English and metric units available

#### APPLICATIONS

- Weather monitoring stations



SERIES PUB & PUF

# PORTABLE ULTRASONIC FLOWMETER KITS

Portable, Non-Invasive and Data Logging Option



PUB



PUF

The Series PUB & PUF Portable Ultrasonic Flowmeter Kits utilize the transit-time difference for measuring flow rates in pipes non-invasively. Units offer flow rate local display with analog and pulsed outputs. The Series PUF offers the same features plus data logging capability.

**FEATURES/BENEFITS**

- Non-invasive pipe measurement
- Compact and lightweight
- Incorporate the latest electronics and signal processing technologies realizing high performance and easy operation
- Ideal for on-the-go flow monitoring, capable of 20 hours continuous operation with built-in, rechargeable battery
- Easy to read graphic display with convenient backlight for visual comfort
- Efficient layout of the function keys for easy to use programming
- PUB features rugged carrying case with molded foam inserts
- PUF boasts an IP67 rated case to hold and protect all equipment conveniently

**APPLICATIONS**

- Water treatment
- Industrial systems
- Irrigation applications
- Treated water flow
- River water
- Sea water
- Potable water
- Demineralized water
- Glycol/water mix
- Hydraulic system
- Diesel oil
- Water use data logging

**KIT INCLUDES**

- Converter
- Set of transducers
- Transducer holders
- Set of transducer cables (6.56' (2 m))
- 4-20 mA communication cables
- 12 VDC power supply
- Ultrasonic coupling grease
- Set of chains
- Ruled guide rail
- Test block
- Carrying case

USA: California Proposition 65

⚠WARNING: Cancer and Reproductive Harm - www.P65Warnings.ca.gov

For more information on these products: See page 290

**MODEL 472A-1**

# DUAL INPUT THERMOCOUPLE THERMOMETER

Accepts J, K, T Thermocouples, Differential Temperature Indication

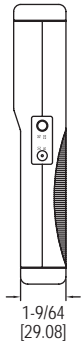
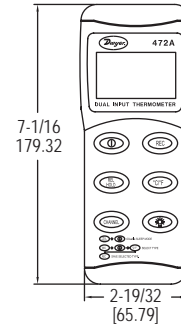
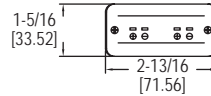

The Model 472A-1 Dual Input Thermocouple Thermometer precisely measures up to two temperature measurements simultaneously. The large LCD display shows both temperature inputs or one temperature input and the differential temperature. Any J, K, or T type thermocouple with a mini-jack connector can be used as an input. For viewing in poorly lit environments, the built-in back light brightens the display. A hold button allows the user to freeze temperature data displayed. Minimum and maximum readings can be recorded over a set time period. Model 472A-1 includes a hard carrying case, battery, and one K type thermocouple.

**SPECIFICATIONS**

**Inputs:** Type J, K, T thermocouples.  
**Power Requirements:** 9 V alkaline battery, installed non-functional, user replaceable.  
**Ranges:** J-type: -328 to 1400°F (-200 to 760°C); K-type: -328 to 2498°F (-200 to 1370°C); T-type: -328 to 734°F (-200 to 390°C).  
**Accuracy:** ±0.1% reading + 1.4°F (0.7°C).  
**Temperature Limits:** 32 to 122°F (0 to 50°C).  
**Humidity Limits (Non-Condensing):** 0 to 85% relative humidity.  
**Display:** Triple LCD display.  
**Resolution:** 0.1°C up to 500°C.  
**Weight:** 23.6 oz.

MODEL CHART	
Model	Description
472A-1	Digital input thermocouple thermometer

OPTIONS	
Use order code:	Description
NISTCAL-TG	NIST traceable calibration certificate

ACCESSORIES	
Model	Description
472A-B	Rubber boot
1818-0074	Immersion probe
1818-0078	Penetration probe
1818-0082	Surface probe
1818-0085	Air duct probe
1718-0077	Remote probe handler

HANDHELD THERMOCOUPLES		
Model	Description	T/C Type
1718-0001	General Purpose Probe: Featuring a built-in handle with coiled cord and mini-plug, this general purpose probe can be used in liquids and air compatible gases. For use to 800°F.	J
1718-0002		K
1718-0014	Penetration Probe: Featuring a built-in handle with coiled cord and mini-plug, this probe is used for penetrating meat, plastic, rubber, asphalt, or other semi-soft materials.	J
1718-0015		K

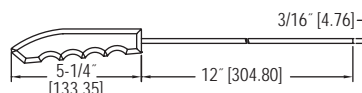

General purpose probe

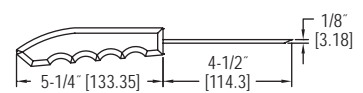

Penetration probe

# GAS PRESSURE TEST KIT

Convenient Kit Perfect For Testing LP and Natural Gas Controls

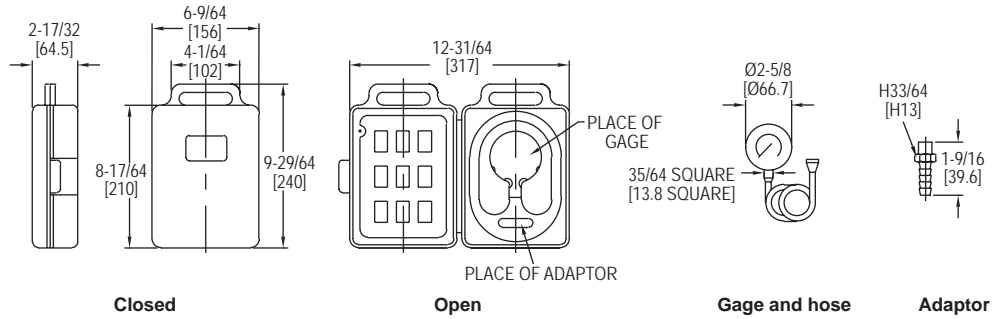

The **Series LPTK Gas Pressure Test Kit** is ideal for testing LP and natural gas lines and controls. The kit's gage shows if proper pressure is present or if a leak exists. Series LPTK is easier to use than a manometer and includes a sturdy case for added durability and safe handling.

**FEATURES/BENEFITS**

- Calibration screw on the back of the gage
- Simple interface for ease of use

**APPLICATIONS**

- Combustion gas supply monitoring and testing

MODEL CHART	
Model	Range
LPTK-01	0 to 15 in w.c. and 0 to 8.6 oz/in <sup>2</sup>
LPTK-02	0 to 32 in w.c. and 0 to 18.5 oz/in <sup>2</sup>
LPTK-03	0 to 4 kPa and 0 to 40 mbar
LPTK-04	0 to 8 kPa and 0 to 80 mbar

**Note:** Consult factory for other range options.

SPECIFICATIONS
<b>Service:</b> Compatible gases.
<b>Wetted Materials:</b> Gage: brass, hose: rubber.
<b>Housing Materials:</b> Steel with black finish.
<b>Lens:</b> Polycarbonate.
<b>Accuracy:</b> ±3% FS.
<b>Pressure Limit:</b> 110% of range.
<b>Temperature Limits:</b> -40 to 150°F (-40 to 65°C).
<b>Size:</b> 2-1/2" (63 mm).
<b>Process Connections:</b> 1/8" NPT, brass hose barb.
<b>Case:</b> ABS plastic.
<b>Hose:</b> Rubber, 36" (91.4 cm).
<b>Tube Nipple:</b> Rubber.
<b>Weight:</b> 1.75 lb (0.8 kg).

**Dwyer**

MODEL TAC-L

**PORTABLE DIGITAL TACHOMETER**

Contact or Photo Non-Contact Operation, Backlit LCD

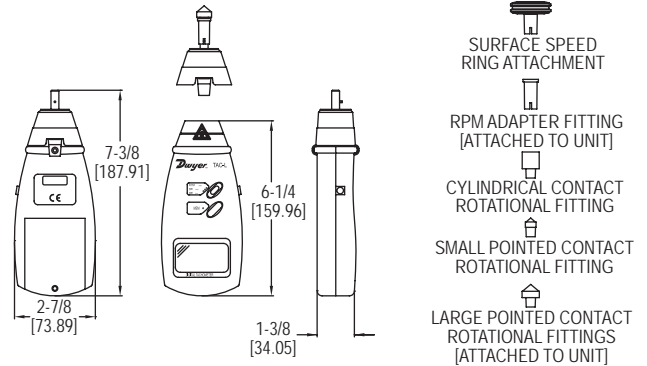

The **Model TAC-L Portable Digital Tachometer** measures rotational speed either by contacting a rotatable head to the shaft of the object or by using a photo sensor to detect the reflections from the laser. The housing is made of a strong, lightweight ABS plastic housing, which is designed to comfortably fit in the hand of the user. Supplied with this model are 3 contact rotational heads, a contact surface wheel, and a protective carrying case.

**FEATURES/BENEFITS**

- Non-contact operation can record from a distance of up to 20 inches
- Memory function recalls records since last power off
- Large backlit LCD for visibility in dark areas

**APPLICATIONS**

- HVAC fan motors
- Powder and bulk conveyor belts

**SPECIFICATIONS**

**Range:** Non-contact (RPM): 2.5 to 99,999 RPM; Contact (RPM): 0.5 to 19,999 RPM; Surface speed (m/min): 0.05 to 1999.9 m/min.  
**Accuracy:**  $\pm(0.05\% + 1 \text{ digit})$ .  
**Display:** Backlit LCD; 5 digits, 7 segments, 0.7" (1.8 cm) H.  
**Resolution:** Non-contact (RPM): 0.1 RPM (2.5 to 999.9 RPM), 1 RPM (1000 to 99,999 RPM); Contact (RPM): 0.1 RPM (0.5 to 999.9 RPM), 1 RPM (1000 to 19,999 RPM); Surface speed (m/min): 0.01 m/min (0.05 to 99.99 m/min), 0.1 m/min (100.0 to 1999.9 m/min).  
**Non-contact Measuring Distance Range:** 2 to 20" (5 to 50 cm).  
**Sampling Time:** 0.8 s.  
**Temperature Limits:** 32 to 122°F (0 to 50°C).  
**Power Requirements:** (4) 1.5 V AA alkaline batteries.  
**Weight:** 1.37 lb (.620 kg).

**MODEL CHART**

Model	Description
TAC-L	Contact/non-contact digital tachometer

**ACCESSORIES**

Model	Description
TAC-5	Reflective tape, 5' (1.5 m) roll, 1/2" (13 mm) wide

**OPTIONS**

Model	Description
NISTCAL-EL1	NIST traceable calibration certificate



# CURRENT/VOLTAGE SIGNAL GENERATOR

Ramp Function, Large Numeric LCD Display

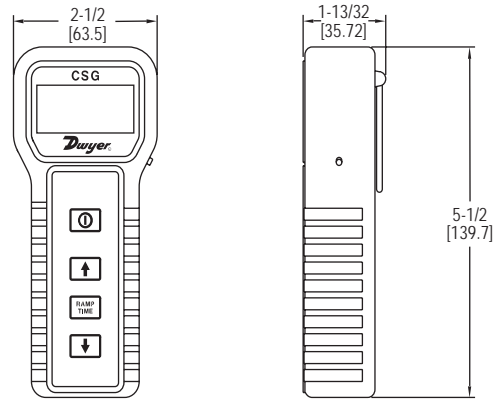

The **Model CSG Current/Voltage Signal Generator** generates a 0-10 VDC signal in increments of 1 V or a 0-20 mA signal in increments of 1 mA. The large LCD features a blue backlight for use in dimly lit areas. Model CSG continuously ramps the output using the user selected minimum, maximum, and ramp interval timing parameters.

**FEATURES/BENEFITS**

- Large backlit LCD for visibility in dark areas
- Timed ramp function
- Auto shut-off to conserve battery life

**APPLICATIONS**

- Troubleshooting transmitters and transducers
- Configuring panel meters

**SPECIFICATIONS**

**Impedance:** Voltage: 1000 Ω min; Current: 300 Ω max.  
**Output:** 0-20 mA (1 mA increments); 0-10 VDC (1 VDC increments).  
**Resolution:** 1 mA (current); 1 VDC (voltage).  
**Ramping Time Intervals:** 1 to 20 s (1 s increments).  
**Ambient Operating Temperature:** 32 to 122°F (0 to 50°C).  
**Power Requirements:** 9 V alkaline battery, included, user replaceable or 120 VAC (provided).  
**Auto Power Off:** 1 to 20 min.  
**Electrical Connections:** 6' (1.8 m) with alligator clips.  
**Weight:** 6 oz (170 g).

**MODEL CHART**

Model	Description
CSG	Current/voltage signal generator

**MODEL ASG**

# ANALOG SIGNAL GENERATOR

Ramp Function, Bar Graph LED, Selectable Auto Shut Off

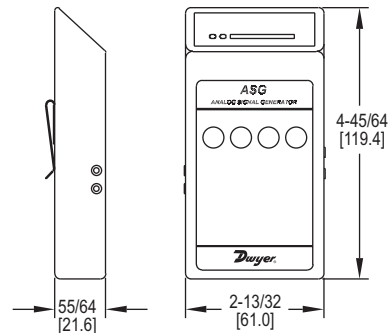

The **Model ASG Analog Signal Generator** generates a 0-10 VDC signal in increments of 1 V or a 4-20 mA signal in increments of 2 mA. An LED bar graph visually indicates the analog signal level. Model ASG will also continuously ramp to user defined maximum and minimum values with user defined ramp interval timing.

**FEATURES/BENEFITS**

- LED bar graph for visibility in dark areas
- Variable ramp function timing
- Auto shut-off to conserve battery life

**APPLICATIONS**

- Troubleshooting transmitters and transducer
- Calibrating transducers, displays, and other analog signal devices

**SPECIFICATIONS**

**Impedance:** Voltage: 1000 Ω min; Current: 300 Ω max.  
**Output:** 0-20 mA (2 mA increments); 0-10 VDC (1 VDC increments).  
**Resolution:** 2 mA (current), 1 VDC (voltage).  
**Ramping Time Intervals:** 2 to 20 sec (2 sec increments).  
**Ambient Operating Temperature:** 32 to 122°F (0 to 50°C).  
**Power Requirements:** 9 V alkaline battery, installed functional, user replaceable or 120 VAC (provided).  
**Auto Shutoff Times:** 2 to 20 min. (2 min. increments) (6 min. default).  
**Electrical Connections:** 6' (1.8 m) with alligator clips.  
**Weight:** 3.2 oz (without battery).

**MODEL CHART**

Model	Description
ASG	Analog signal generator

**Dwyer**

MODEL HP

# HAND PUMP

Generates Pressures up to 45 psig (3 bar), Single Hand Operation

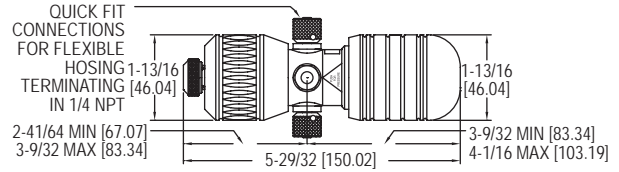

The **Model HP Hand Pump** provides a dual source of pneumatic pressure and vacuum for verifying the calibration of pressure instrumentation. Pump can generate pressures up to 45 psig (3 bar) and vacuum to -27 in Hg (-910 mbar). The compact pump is designed for portability and single hand operation.

Model HP features a pressure relief valve and fine adjustment for control better than 0.0015 psi (0.1 mbar). Pump includes two 39" (1 m) hoses terminating in 1/4" female NPT connections and instruction manual.

**FEATURES/BENEFITS**

- Offers vacuum or positive pressure sourcing
- Compact and portable
- Integral relief valve for fine adjustment
- Reference gage recommendation: DPG-022

**APPLICATIONS**

- Test instrument calibration
- Pressure switch calibration
- Pressure transmitter calibration

**MODEL CHART**

Model	Description
HP	Hand pump

**ACCESSORIES**

Model	Description
HP-1K	Service kit
HP-1C	Hard case

USA: California Proposition 65

⚠WARNING: Cancer and Reproductive Harm - [www.P65Warnings.ca.gov](http://www.P65Warnings.ca.gov)**SERIES CHP**

# PNEUMATIC HAND PUMP

Vacuum or Pressure, Ranges up to 100 psig

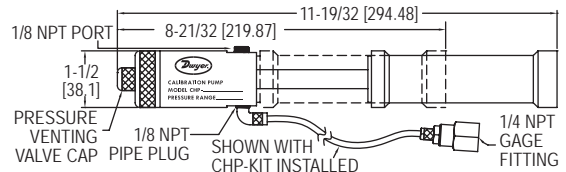

The **Series CHP Pneumatic Hand Pump** is the most dependable and rugged pump for applications up to 100 psi or 28.8 in Hg vacuum. The durable Acetal plastic and anodized aluminum construction prevents body heat transfer, resulting in drift-free, accurate readings. The Series CHP is equipped with oversized check valves in order to provide smooth and controlled operation. Dual O-Rings on all pistons ensure the pump to be leak-free. The unit includes a 2' L hose, 1/8" female NPT gage fitting, and 1/8" NPT pipe plug. An optional hose kit is available so that a tee is not required when connecting a sensor and a calibrator. The Series CHP is ideal for checking calibration of pressure or vacuum gages, switches, or transmitters.

**FEATURES/BENEFITS**

- Offers vacuum or positive pressure sourcing
- Compact and portable
- Integral relief valve for fine adjustment
- Reference gage recommendation: DPG-024

**APPLICATIONS**

- Test instrument calibration
- Pressure switch calibration
- Pressure transmitter calibration

**MODEL CHART**

Model	Description
CHP-P	Pressure calibration pump
CHP-V	Vacuum calibration pump

**ACCESSORIES**

Model	Description
CHP-KIT	2' hose and NPT fitting



MODEL A-396A

# CALIBRATION PUMP

Generates up to 72 psig, Integral Bleed Fitting

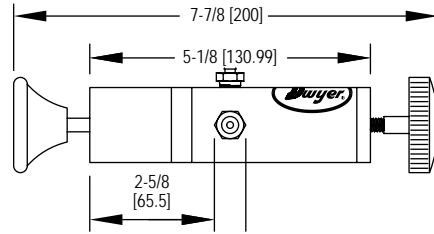

The **Model A-396A Calibration Pump** serves as pressure source to calibrate gages and transmitters or to set pressure switches. Use with manometer or other pressure standard. Includes volume adjuster enabling fine pressure control and bleed valve. Generates pressures from a fraction of an in w.c. to 72 psig (5 bar). Includes barbed fitting, tee connector and three 36" lengths of vinyl tubing.

MODEL CHART	
Model	Description
A-396A	Calibration pump

### FEATURES/BENEFITS

- Offers wide pressure sourcing capability
- Compact and portable
- Integral relief valve for fine adjustment
- Reference gage recommendation: DPG-024

### APPLICATIONS

- Test instrument calibration
- Pressure switch calibration
- Pressure transmitter calibration

MODEL A-350

# ASPIRATOR BULB

Single Hand Operation, Vacuum or Pressure



The **Model A-350 Aspirator Bulb** can be used to source pressure for calibration and leak checking tests. Simply squeeze the bulb after the tubing is connected to generate pressure. For applications such as our CO<sub>2</sub> indicator, the aspirator bulb can be squeezed before inserting the tubing to draw a vacuum to pull the smoke or air from a duct or stack into the gage.

MODEL CHART	
Model	Description
A-350	Aspirator bulb

### FEATURES/BENEFITS

- Offers vacuum or positive pressure sourcing
- Compact and portable
- Most cost effective option
- Reference gage recommendation: Magnehelic 2010

### APPLICATIONS

- Test instrument calibration
- Pressure switch calibration
- Pressure transmitter calibration
- Smoke leak testing



SERIES PCHP

# PNEUMATIC CALIBRATION HAND PUMP

Generates up to 600 psi (40 bar), Comfort Grip Handles

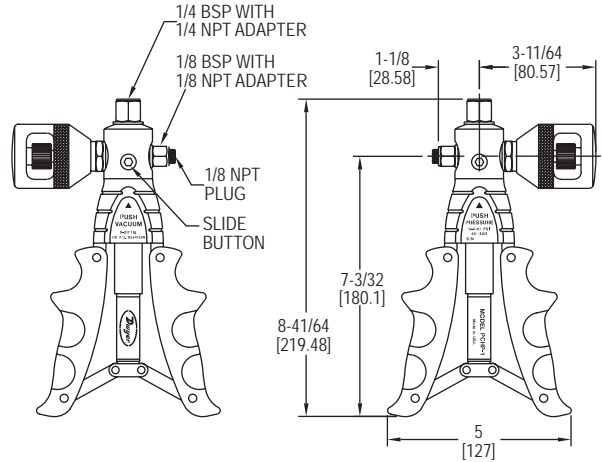

The **Series PCHP Pneumatic Calibration Hand Pump** sources pressure and vacuum to check calibration of gages, switches, transmitters, and recorders. The contoured cushion handles provide extra comfort while preventing the pump from sliding.

**FEATURES/BENEFITS**

- Oversized check valve maintain smooth operation
- Dual O-rings on pistons ensure no leaks

**APPLICATIONS**

- Instrument calibration
- Laboratories
- Production areas

MODEL CHART	
Model	Description
PCHP-1	Pneumatic calibration hand pump
PCHP-1K	Pneumatic calibration hand pump with hose kit

**SPECIFICATIONS**

**Output Ranges:** -28 in Hg to 600 psi (-0.945 to 40 bar).  
**Process Connection:** 1/4" NPT/BSP.  
**Gage Connection:** 1/8" NPT/BSP.  
**Materials:** SS fittings, anodized aluminum housing, plastic/rubber handles, and nitrile O-rings.  
**Weight:** 2 lb (0.91 kg).

**ACCESSORIES**

Model	Description
PCHP-HK	High pressure hose

SERIES HCHP

# HYDRAULIC CALIBRATION HAND PUMP

Triple Filtration, Generates Pressure up to 10,000 psi (700 bar)

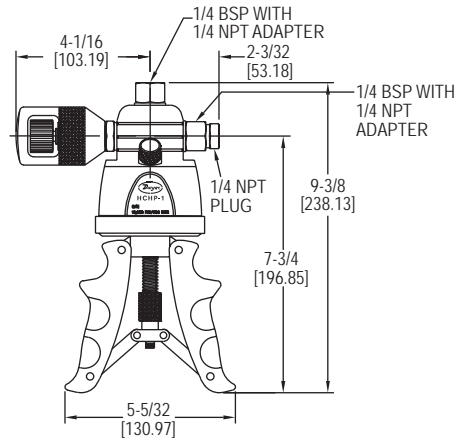

The **Series HCHP Hydraulic Calibration Hand Pump** utilizes a fully adjustable stroke control that allows for quick priming, easy pumping, and fast pressure generation up to 10,000 psi (700 bar). The ergonomically engineered handles provide extra comfort, while the triple filtration system ensures pump operation in spite of dirty conditions.

**FEATURES/BENEFITS**

- Oversized check valve maintain smooth operation
- Shatterproof reservoir and stainless steel construction guarantee no leaks

**APPLICATIONS**

- Instrument calibration
- Laboratories
- Production areas

MODEL CHART	
Model	Description
HCHP-1	Calibration hand pump
HCHP-1K	Calibration hand pump with hose kit

**SPECIFICATIONS**

**Output Ranges:** 0 to 10,000 psi (0 to 700 bar).  
**Process Connection:** 1/4" NPT/BSP.  
**Gage Connection:** 1/4" NPT/BSP.  
**Materials:** SS, polyurethane, anodized hard-coat aluminum, PTFE, and nitrile.  
**Weight:** 3 lb (1.36 kg).

**ACCESSORIES**

Model	Description
HCHP-1F	Spare washer and filter kit

# LOW PRESSURE CALIBRATION PUMP

High Resolution for Calibrating Low Pressure Gages and Transmitters

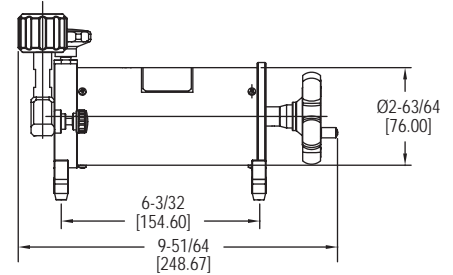
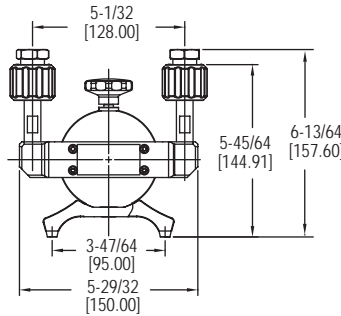

The **Model LPCP Low Pressure Calibration Pump** is a low air pressure source with the ability to easily adjust and stabilize. It is made up of quick connectors for fast instrument connect and disconnect.

**FEATURES/BENEFITS**

- Heat insulator between the cover and pressure chamber lessens the heat effect during micro-pressure calibration
- Highly stable adjustment

**APPLICATIONS**

- Instrument calibration
- Laboratories
- Production areas

MODEL CHART	
Model	Description
LPCP-2	Low pressure calibration pump

**SPECIFICATIONS**

**Media:** Air.  
**Output Ranges:** 5.8 psi (0.4 bar) vacuum to 5.8 psi (0.4 bar) positive pressure.  
**Pressure Resolution:** 0.01 Pa; 0.0001 mbar.  
**Process Connection:** M20\*1.5 or 1/4" NPT.  
**Gage Connection:** M20\*1.5 or 1/4" NPT.  
**Material:** Ram/adapters: 316 SS; Body: Steel/aluminum; Seals: Buna-N.  
**Weight:** 2.21 lb (1.0 kg).

**ACCESSORIES**

Model	Description
A-113A	Fitting kit. Includes (1) 1/4" NPT to 1/8" quick connect fitting, (1) 1/4" NPT to hose barb fitting, (1) hose barb fitting to 1/8" quick connect fitting, (2) 19.7" (0.5 m) length of blue 1/8" O.D. tubing, (2) 12" (0.3 m) length of clear 1/4" O.D. tubing

USA: California Proposition 65  
 ⚠WARNING: Cancer and Reproductive Harm - www.P65Warnings.ca.gov

**SERIES BCHP**

# LOW PRESSURE CALIBRATION PUMP

Vacuum or Pressure, Generates up to 870 psi (60 bar)

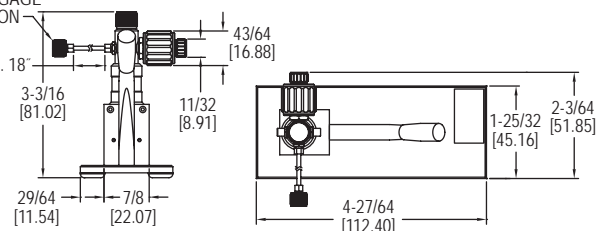
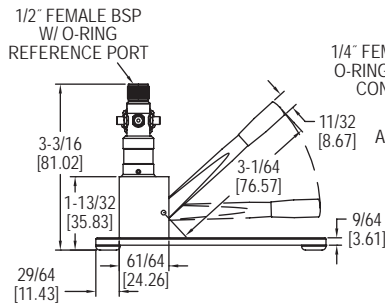

The **Series BCHP Low Pressure Calibration Pump** is able to generate pressure and vacuum for adjusting or calibrating pressure gages, transmitters, or switches. The pump is hand operated and has a pneumatic pressure range of -28 to 870 psi (-0.95 to 60 bar).

**FEATURES/BENEFITS**

- Dual pressure ports for ease of use
- Fine adjustment valve ensures precise measurements

**APPLICATIONS**

- Instrument calibration
- Laboratories
- Production areas

MODEL CHART	
Model	Description
BCHP-1	Calibration test pump
BCHP-KIT	Test pump with 1/4" NPT connections, fine volume adjustment tool and case

**SPECIFICATIONS**

**Media:** Air.  
**Output Ranges:** -28 in Hg to 870 psi (-0.95 to 60 bar).  
**Process Connections:** 1/4" female BSP.  
**Gage Connection:** 1/2" female BSP.  
**Materials:** Anodized aluminum, brass, and ABS.  
**Weight:** 8.4 lb (3.8 kg).

**ACCESSORIES**

Model	Description
A-BCHP-CASE	Case for BCHP-1
A-BCHP-NPT	1/4" BSP to 1/8" NPT, 1/4" NPT, 3/8" NPT and 1/2" NPT converter set for test connection
A-BCHP-VAT	Fine volume adjustment tool

USA: California Proposition 65  
 ⚠WARNING: Cancer and Reproductive Harm - www.P65Warnings.ca.gov



SERIES DW-USB

# COMPACT USB DATA LOGGER

Measure Temperature, Humidity, Dew Point, Current, Voltage, or Carbon Monoxide

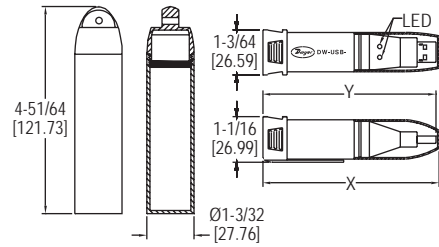

Model DW-USB-CASE Model DW-USB-X

Model	Overall Length (X)	Overall Length (Y)	Body/Clip	Cap	LED
DW-USB-1	3-55/64"	3-55/64"	Standard	Standard	Clear/red
DW-USB-2, -2-HA	4-1/16"	4-1/16"	Vented	Standard	Clear/clear
DW-USB-3	4-27/64"	4-27/64"	Standard	Black tip term block	Red/green
DW-USB-4	4-27/64"	4-27/64"	Standard	Blue tip term block	Red/green
DW-USB-5, -5-LR	4-59/64"	4-59/64"	Vented	Red tip CO sensor	Red/green
DW-USB-6	4-21/32"	4-21/32"	Standard	Standard	Red/green

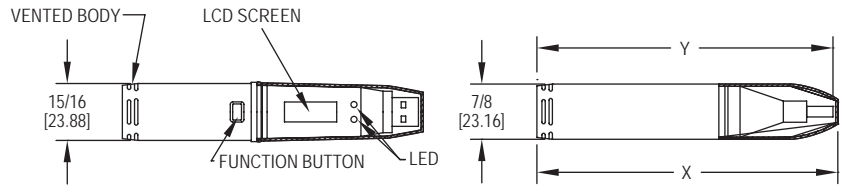

Model	Overall Length (X)	Overall Length (Y)	Body/Clip	Cap	LED
DW-USB-1-LCD	4-21/32"	4-41/64"	Standard	Transparent	Red/green
DW-USB-2-LCD	4-31/32"	4-57/64"	Vented	Transparent	Red/green
DW-USB-2-HA-LCD	4-31/32"	4-57/64"	Vented	Transparent	Red/green
DW-USB-6-LCD	5-19/64"	5-15/64"	Plug in bottom	Transparent	Red/green

The Series DW-USB Compact USB Data Logger allows users to monitor temperature, humidity, dew point, voltage, current, or carbon monoxide almost anywhere, and then download stored data by simply plugging the module directly into a PC's USB port. The compact housing can resist moisture up to IP67 when the protective cap is attached, and has built in LED's to indicate an alarm has been met or the battery is low. Users can set the sampling rate, start time, high/low alarms, and temperature unit via software available for free download from our website.

**FEATURES/BENEFITS**

- Meets IP67 standards when the protective cap is fitted
- All in one unit plugs into PC with no cable required
- LED status indicators for visual confirmation
- Optional integral LCD display for local indication

**APPLICATIONS**

- Calibration labs
- Environmental chambers
- Pharmaceutical plants
- Storage warehouses

**SPECIFICATIONS**

**Memory Size:** 16,382 temperature; 16,382 each temperature and RH; 32,764 readings for voltage, current, and thermocouple; and 32,510 for carbon monoxide.  
**Sampling Mode:** Stop on memory full.  
**Sampling Rate:** Selectable from 10 s to 12 hr (temperature and RH models); 1 s to 12 hr (voltage, current, and thermocouple models); 10 s to 5 m (CO models).

**Computer Requirements:** Compatible with Windows® 7, Windows® 8 and Windows® 10.  
**Power Requirements:** 3.6 V 1/2 AA lithium metal battery, included, user replaceable.  
**Housing:** ABS plastic blend.  
**Alarms:** Programmable high/low.  
**Interface:** USB port.  
**Weight:** 1.5 oz (43 g).

**ACCESSORIES**

Model	Description
DW-USB-CASE	Waterproof case for DW-USB-1
1818-0074	Immersion temperature probe
1818-0078	Penetration temperature probe
1818-0082	Surface temperature probe
1818-0085	Air duct temperature probe
1718-0077	Remote temperature probe handle

**MODEL CHART**

Model	Sensor Type	Range	Accuracy	Resolution
DW-USB-1	Temperature	-31 to 176°F (-35 to 80°C)	±2°F (±1°C)	1°F (0.5°C)
DW-USB-2	Temperature/humidity/dew point	-31 to 176°F (-35 to 80°C), 0 to 100% RH	±4°F (2°C), ±3% RH from 20 to 80% RH, ±5% RH	1°F (0.5°C), 0.5% RH
DW-USB-2-HA	Temperature/humidity/dew point	-31 to 176°F (-35 to 80°C), 0 to 100% RH	±3°F (1.5 °C), ±2% RH from 20 to 80% RH, ±4% RH	1°F (0.5°C), 0.5% RH
DW-USB-3	Voltage	0-30 VDC	±1%	50 mVDC
DW-USB-4	Current	4-20 mA	±1%	0.05 mA
DW-USB-5	Carbon monoxide	0 to 1000 PPM	±6% of reading	0.5 PPM
DW-USB-5-LR	Carbon monoxide	0 to 300 PPM	±4% of reading	0.5 PPM
DW-USB-6	External thermocouple	With supplied probe: 32 to 752°F (0 to 400°C) J-type: -202 to 1652°F (-130 to 900°C); K-type: -328 to 2372°F (-200 to 1300°C); T-type: -328 to 662°F (-200 to 350°C)	±2°F (1°C) (for data logger only)	1°F (0.5°C)
DW-USB-1-LCD	Temperature	-31 to 176°F (-35 to 80°C)	±3°F (1.5°C)	1°F (0.5°C)
DW-USB-2-LCD	Temperature/humidity/dew point	-31 to 176°F (-35 to 80°C), 0 to 100% RH	±4°F (2°C), ±3% RH from 20 to 80% RH, ±5% RH	1°F (0.5°C), 0.5% RH
DW-USB-2-HA-LCD	Temperature/humidity/dew point	-31 to 176°F (-35 to 80°C), 0 to 100% RH	±3°F (1.5 °C), ±2% RH from 20 to 80% RH, ±4% RH	1°F (0.5°C), 0.5% RH
DW-USB-6-LCD	External Thermocouple	With supplied probe: 32 to 752°F (0 to 400°C) J-type: -202 to 1652°F (-130 to 900°C); K-type: -328 to 2372°F (-200 to 1300°C); T-type: -328 to 662°F (-200 to 350°C)	±2°F (1°C) (for data logger only)	1°F (0.5°C)

Windows® is a registered trademark of Microsoft Corporation.

# LCD PRESSURE DATA LOGGER

1/4" NPT Fitting, Records 262,143 Readings, Front Keypad

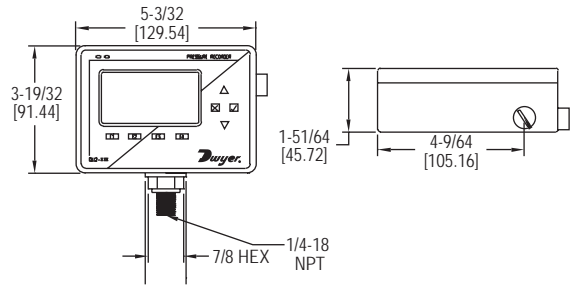

The Series DLI2 LCD Pressure Data Logger accurately records pressure and gives instant remote readings. The large, back-lit LCD and 8-button keypad provide convenient access to current data and recorder setup as well as memory and battery levels. The Series DLI2 can be ordered for absolute or gauge pressure measurements up to 5,000 psi. Using the keypad or software, measurements can be read in psi, in. Hg, mm Hg, bar, atm, Torr, Pa, kPa, or MPa. The large memory capacity allows over 260,000 readings to be stored. The easy to use DL700 software makes creating permanent records, performing data calculations, and graphing of data simple. The DLI2 can easily be started and stopped from a PC or delayed to start up to six months in advance. It can also stop recording at a specific time or after a certain number of readings have been taken.

**FEATURES/BENEFITS**

- Efficient data capture tool to review processes are running correctly or to analyze alarm and out-of-spec conditions
- Intuitive keypad interface allows easy set-up
- PC start and stopping allows centralized control of data collection

**APPLICATIONS**

- Building automation
- Clean room
- Operating rooms
- Process applications
- Labs
- Regulated environments

MODEL CHART			
Model	Pressure Range	Model	Pressure Range
DLI2-A08	0 to 30 psia	DLI2-G13	0 to 300 psig
DLI2-G08	0 to 30 psig	DLI2-A14	0 to 500 psia
DLI2-A10	0 to 100 psia	DLI2-G14	0 to 500 psig
DLI2-G10	0 to 100 psig	DLI2-A15	0 to 1000 psia
DLI2-A13	0 to 300 psia	DLI2-A19	0 to 5000 psia

**SPECIFICATIONS**

**Ranges:** 0 to 30 psia (g), 0 to 100 psia (g), 0 to 300 psia (g), 0 to 500 psia (g), 0 to 1000 psia, and 0 to 5000 psia depending on the model.  
**Memory Size:** 262,143 readings.  
**Accuracy:** 2% FSR, 0.25% at 77°F (25°C) typical.  
**Resolution:** 0.002 psi (30 psi), 0.005 psi (100 psi), 0.02 psi (300 psi), 0.05 psi (500 and 1000 psi), and 0.2 psi (5000 psi) depending on model.  
**Sampling Method:** Stop on memory full or continuous recording.  
**Sampling Rate:** Selectable from 2 s to 12 hrs.  
**Computer Requirements:** Windows® 95, Windows® 98, Windows® 2000, Windows® ME, Windows NT®, or Windows® XP operating system, and one free USB port.  
**Power Requirements:** (6) AA alkaline batteries, installed functional, user replaceable.  
**Battery Life:** 1 yr (approx).  
**Interface:** USB port (interface cable required).  
**Housing Material:** Black anodized aluminum case.  
**Wetted Material:** 316L SS.  
**Enclosure Rating:** IP65.  
**Weight:** 40 oz (1134 g).

**ACCESSORIES**

Model	Description
DL700	Software, manual and USB interface cable
DLI-120	9 V power adapter (North America)

Windows®, Windows NT®, and Windows Vista® are registered trademarks of Microsoft Corporation.

**SERIES DLP**

# PRESSURE/TEMPERATURE DATA LOGGER

1/4" NPT Fitting, Up to 5000 psia

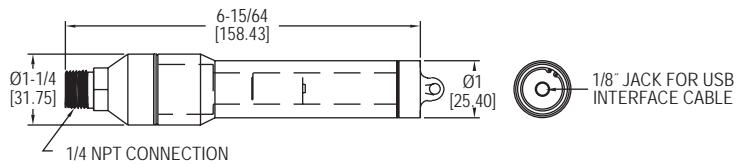

The Series DLP Pressure/Temperature Data Logger can record pressure and temperature. The 1/4" NPT fitting comes standard and allows the logger to be adapted to almost any pressure fitting. The internal temperature sensor provides accurate temperature measurements without the need of a separate temperature recorder, and many of the models provide a choice between measuring pressure in psia or psig. The DLP can easily be started and stopped from a PC or delayed to start up to six months in advance. The battery-powered data logger can store over 16,000 measurements per channel, and the easy to use DL700 software makes retrieving data simple.

**FEATURES/BENEFITS**

- Efficient data capture tool to review processes are running correctly or to analyze alarm and out-of-spec conditions
- Battery-powered reduces need to hard wire power allowing device to be used in a tool in a variety of in-and-out testing
- PC start and stopping allows centralized control of data collection

**APPLICATIONS**

- Building automation
- Clean room
- Operating rooms
- Process applications
- Labs
- Regulated environments

MODEL CHART			
Model	Pressure Range	Model	Pressure Range
DLP-A08	0 to 30 psia	DLP-G13	0 to 300 psig
DLP-G08	0 to 30 psig	DLP-A14	0 to 500 psia
DLP-A10	0 to 100 psia	DLP-G14	0 to 500 psig
DLP-G10	0 to 100 psig	DLP-A15	0 to 1000 psia
DLP-A13	0 to 300 psia	DLP-A19	0 to 5000 psia

**SPECIFICATIONS**

**Range:** Temperature: -40 to 176°F (-40 to 80°C); Pressure: 0 to 30 psia(g), 0 to 100 psia(g), 0 to 300 psia(g), 0 to 500 psia(g), 0 to 1000 psia, and 0 to 5000 psia depending on the model.  
**Memory Size:** 16,383 readings per channel.  
**Accuracy:** Temperature: ±0.9°F (±0.5°C); Pressure: 2% FSR, 0.25% at 77°F (25°C) typical.  
**Resolution:** Temperature: 0.2°F (0.1°C); Pressure: 0.002 psia(g), 0.005 psia(g), 0.05 psia(g), 0.05 psia, and 0.2 psia depending on the model.  
**Sampling Method:** Stop on memory full.  
**Sampling Rate:** Selectable from 2 s to 12 hrs.  
**Computer Requirements:** Windows® 95, Windows® 98, Windows® 2000, Windows® ME, Windows NT®, and Windows® XP operating system, one free USB port.  
**Power Requirements:** 3.6 V TL2150 lithium metal battery, installed functional, user replaceable.  
**Battery Life:** 1 yr (approx).  
**Interface:** USB port (interface cable required).  
**Material:** 303 SS.  
**Weight:** 12 oz (340 g).

**ACCESSORIES**

Model	Description
DL700	Software, manual and USB interface cable
TL-2150	Replacement battery for Series DLP

Windows® is a registered trademark of Microsoft Corporation



SERIES LCR10 & LCR20



# CIRCULAR CHART RECORDERS

Single and Dual Pen, Rotation Speeds and Recording Times



LCR10



LCR20

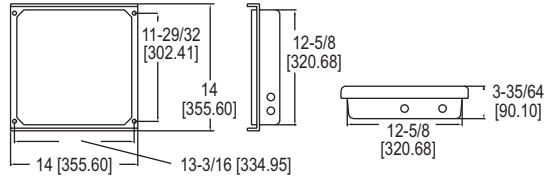

The Series LCR10 & LCR20 Circular Chart Recorders are two series of circular chart recorders with single and dual pen options. The LCR10 is a single pen recorder and the LCR20 is a dual pen. They can be easily programmed for any of six different thermocouple types, 100 ohm platinum DIN RTDs, or process inputs.

**FEATURES/BENEFITS**

- Uses large 10" (254 mm) circular chart to easily read data
- Available with dual pen inputs

**APPLICATIONS**

- Water level monitoring in water treatment
- Temperature/humidity in wood drying
- Room pressure monitoring in clean room applications

**SPECIFICATIONS**

**Ranges:** Thermocouple: Type J, K, T, R, S, B; RTD: 100 Ω platinum DIN curve (0.00385 Ω per Ω per °C); Process: 0 to 5 VDC, 250 Ω impedance, 4 to 20 mA across 250 Ω.  
**Chart Size:** 10" (254 mm).  
**Accuracy:** ±0.5% of span (100 division span).  
**Output Relay:** Form C (DPDT), 1A @ 240 VAC resistive.  
**Chart Speed:** Programmable 4, 8, 12, 24, 48, 72, 168 hour rotation (168 hours=7 days).

**Ambient Operating Temperature/RH:** 32 to 140°F (0 to 60°C); 0-90% RH (non-condensing).  
**Power Requirements:** 110/220 VAC ±10%.  
**Battery Backup:** 9 V alkaline battery, installed functional, user replaceable.  
**Power Consumption:** 15 VA max.  
**Housing Material:** Fire retardant polyphenylene ether and polystyrene PPE & PS with acrylic window.  
**Mounting:** ±20 degrees of vertical, ±10 degrees of horizontal.  
**Weight:** 7 lb (3.2 kg).  
**Agency Approvals:** CE.

**MODEL CHART**

Model	Rotation	Pen Inputs	Output
LCR10-101	Counter-clockwise	Single	No
LCR10-111	Counter-clockwise	Single	Yes
LCR20-101	Counter-clockwise	Dual	No
LCR20-111	Counter-clockwise	Dual	Yes

**ACCESSORIES**

Model	Description
LCR200	Chart paper, 0 to 200°F, 24 hour, CCW
LCR2007	Chart paper, 0 to 200°F, 7 day, CCW
LCR110C	Chart paper, 0 to 110°C, 24 hour, CCW
LCR-R	Red chart pens, package of 6
LCR-B	Blue chart pens, package of 6

**MODEL HTDL-20/30**

# HIGH TEMPERATURE DATA LOGGER

Submersible, Continuous Recording, User Replaceable Battery

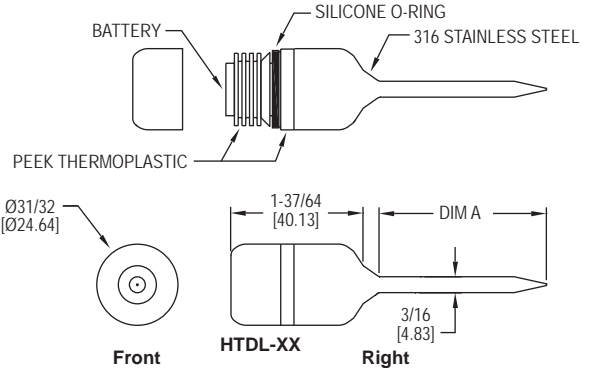

The Model HTDL-20/30 High Temperature Data Logger can measure temperatures up to 500°F (260°C) and record up to 32,700 measurements.

**FEATURES/BENEFITS**

- Submersible and portable
- Temperature measurement up to 500°F
- Remote probe option for chamber or oven logging
- Delay startup timer

**APPLICATIONS**

- Thermal testing
- Process monitoring or troubleshooting

**MODEL CHART**

Model	Description
HTDL-20	High temperature data logger with 2" rigid probe
HTDL-30	High temperature data logger with 24" flexible probe

**SPECIFICATIONS**

**Range:** -328 to 500°F (-200 to 260°C).  
**Memory Size:** 32,700 readings.  
**Accuracy:** 0.18°F (0.1°C) @ 68 to 284°F (20 to 140°C); 0.54°F (0.3°C) @ -4 to 67.98°F (-20 to 19.99°C).  
**Resolution:** 0.02°F (0.01°C).  
**Temperature Limits:** -4 to 284°F (-20 to 140°C).  
**Sampling Method:** Stop on memory full or continuous recording.  
**Sampling Rate:** Selectable from 1 s to 24 hrs.

**Computer Requirements:** Windows® Xp Sp3, Windows Vista®, Windows® 7 operating systems.  
**Power Requirements:** 3.6 V 1/2 AA ER14250SM lithium metal battery, installed functional, user replaceable.  
**Battery Life:** 1 year (approx).  
**Interface:** Docking station and USB cable.  
**Housing Material:** 316 SS.  
**Weight:** 4.2 oz (120 g).

**ACCESSORIES**

Model	Description
HTDL-DS	Docking station, software, manual and USB interface
ER1425S-HT	Replacement battery

Windows® and Windows Vista® are registered trademarks of Microsoft Corporation.



# GRAPHICAL DISPLAY DATA LOGGER

Measure Temperature, Humidity and Dew Point, Instant Display

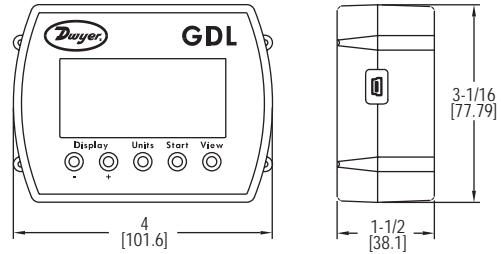

The **Model GDL Graphical Display Data Logger** can record and instantly display temperature, humidity, and dew point trends in a text or graphic format. The GDL has internal temperature and humidity sensors while the **Model GDL-T Graphical Display Data Logger** accepts up to 3 external temperature sensors. With the included Windows® based software, the user can select the sampling interval, high/low alarms, logging channels, and recording start time. Over 40,000 data points can be recorded and the measured data stays secure with a recording session counter and password-protected calibration.

**FEATURES/BENEFITS**

- Measurements displayed in text or graph
- Able to record over 40,000 data points and download them to a PC
- Includes logging summary with details of the sample rate and memory status

**APPLICATIONS**

- Greenhouses/florists
- Medical storage facilities
- Refrigeration systems
- Wine storage

**MODEL CHART**

Model	Description
GDL	Temperature/humidity data logger
GDL-T	Four temperature sensor data logger

**SPECIFICATIONS**

**Memory Size:** 43,344 temperature; 21,672 temperature, RH and dew point.  
**Temperature Range:** 15 to 150°F (-10 to 65°C).  
**Temperature Accuracy:** ±1°F (±0.5°C).  
**Temperature Resolution:** 0.01°F (0.01°C).  
**Humidity Range:** 0 to 99% RH.  
**Humidity Accuracy:** ±2% RH, from 10 to 90% RH.  
**Humidity Resolution:** 0.01% RH.  
**Sampling Method:** Stop on memory full or continuous recording.  
**Sampling Rate:** 1 s to 18 hrs, 1 s increments.  
**Computer Requirements:** Windows® 98 and above (software included).  
**Power Requirements:** (3) AA alkaline batteries, installed functional, user replaceable.  
**Alarms:** Programmable high/low.  
**Interface:** USB port (cable included).  
**Weight:** 7 oz (20 g).  
**Agency Approvals:** CE.

Windows® is a registered trademark of Microsoft Corporation

**SERIES BDL**

# BUTTON DATA LOGGER

Self-Powered, Compact Size, USB Interface

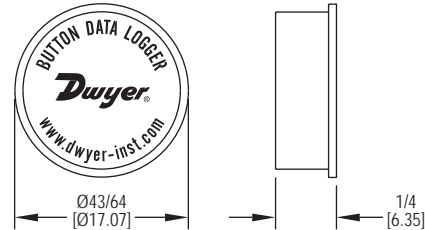

The **Series BDL Button Data Logger** records temperature and humidity in applications where size and cost effectiveness are vital. Housed in a compact stainless steel case, the BDL is durable in hostile environments, while also being able to be inserted in small items and packages. The Series BDL-K Logger Kit includes 2 buttons, 2 magnets, an interface cable, and a plastic button holder.

**FEATURES/BENEFITS**

- Compact to fit in small areas and durable to work in hostile environments
- Self-powered unit gives no need for external power supply
- Magnetic mounting for quicker installation

**APPLICATIONS**

- Food processing verification
- Pharmaceutical storage
- HVAC system testing and balancing
- Transportation of temperature sensitive goods

**ACCESSORIES**

Model	Description
DL500-LITE*	Lite version Windows® operating system software
DL500**	Full version Windows® operating system software key
BDL-SIL	Weatherproof silicone housing (5 pk)
BDL-WALL	Wall mounting bracket (5 pk)
BDL-CLIP	Plastic button holder (5 pk)
BDL-1	Temperature input data logger, no kit
BDL-2	Temperature/humidity input data logger, no kit

\*Free download from website \*\*Need lite version also

**SPECIFICATIONS**

**Range:** BDL-1: -40 to 185°F (-40 to 85°C); BDL-2: -4 to 185°F (-20 to 85°C), 0 to 100% RH.  
**Memory Size:** BDL-1: 2048 readings; BDL-2: 4096 temperature and 4096 humidity readings (low resolution), 2048 temperature and 2048 humidity readings (high resolution).  
**Accuracy:** BDL-1: ±1.5°F (±1°C) from -22 to 158°F (-30 to 70°C); BDL-2: ±0.9°F (±0.5°C) from 14 to 158°F (-10 to 70°C), ±5% RH.  
**Resolution:** BDL-1: 8 bit; BDL-2: 8 or 11 bit.  
**Sampling Method:** Stop on memory full or continuous recording.  
**Sampling Rate:** BDL-1: Selectable from 1 to 255 min.; BDL-2: Selectable from 1 s to 24 hrs.  
**Computer Requirements:** Windows® 98, Windows® 2000, Windows® ME, Windows NT®, Windows® XP, and Windows Vista® operating system with 16 MB RAM, one free USB port.  
**Power Requirements:** 3 V lithium metal battery, internal, non-replaceable.  
**Battery Life:** BDL-1: 10 years (approx); BDL-2: 5 years (approx).  
**Alarms:** Programmable high/low.  
**Interface:** USB port (cable included with kits).  
**Housing Material:** 305 SS.  
**Weight:** 0.14 oz (4 g).

**MODEL CHART**

Model	Input Type	Kit
BDL-K1	Temperature	Yes
BDL-K2	Temperature/humidity	Yes

Windows®, Windows NT®, and Windows Vista® are registered trademarks of Microsoft Corporation.

**Dwyer**

SERIES DW-WIFI

**WIRELESS WI-FI DATA LOGGER**

Measures Temperature/Humidity, Integral LCD

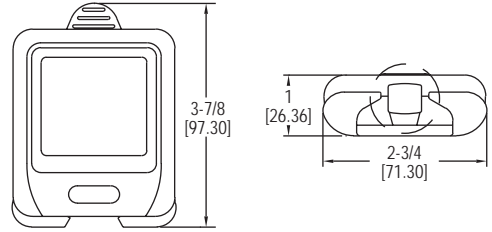

The **Series DW-WIFI Wireless Wi-Fi Data Logger** measures and records up to 1,000,000 temperature and/or humidity readings and shares the data with any PC or server on the same Wi-Fi network. If the Wi-Fi connection is lost, the sensor will continue to store any records until it can regain communication with the network. The downloadable Windows® based software allows users to set high/low alarms, sampling rate, and the temperature scale.

**FEATURES/BENEFITS**

- Continues to record values even if Wi-Fi connection is lost
- Able to record up to 1,000,000 data points, which can be downloaded to a PC
- Large LCD allows users to view data directly from unit

**APPLICATIONS**

- Building/site monitoring
- Environment monitoring
- Weather monitoring

**SPECIFICATIONS**

**Memory Size:** 1,000,000 readings; 500,000 each for DW-WIFI-TH(-HA).  
**Sampling Mode:** Continuous recording.  
**Sampling Rate:** Selectable from 10 s to 12 hr.  
**Transmission Rate:** Selectable from 1 min to 24 hr.  
**Temperature Limits:** -4 to 140°F (-20 to 60°C).  
**Power Requirements:** 3.7 V lithium ion battery, installed functional, factory replaceable (cable for charging included).  
**Alarms:** Programmable high/low.  
**Interface:** Wi-Fi connection.  
**Probe Length:** DW-WIFI-TP: 11.8" (30 cm); DW-WIFI-TC: 59" (150 cm).  
**Weight:** 7.2 oz (204 g).

**MODEL CHART**

Model	Input	Range	Accuracy (Typ.)	Display Resolution
DW-WIFI-T	Internal temperature	-4 to 140°F (-20 to 60°C)	±1.0°F (±0.5°C) @ 14 to 122°F (-10 to 50°C)	0.1°F (0.1°C)
DW-WIFI-TH	Internal temperature/humidity	-4 to 140°F (-20 to 60°C), 0 to 100% RH	±0.6°F (±0.3°C) @ 41 to 140°F (5 to 60°C) ±2.5% RH @ 20 to 80% RH	0.5°F (0.5°C) 1.0% RH
DW-WIFI-TP	Remote temperature probe	-40 to 257°F (-40 to 125°C)	±1.2°F (±0.6°C) @ 14 to 158°F (-10 to 70°C)	0.1°F (0.1°C)
DW-WIFI-TC	Remote thermocouple	-454 to 2372°F (-270 to 1300°C)*	±3.0°F (1.5°C)	0.1°F (0.1°C)
DW-WIFI-T-HA	Internal temperature	-4 to 140°F (-20 to 60°C)	±0.2°F (±0.1°C) @ 14 to 140°F (-10 to 60°C)	0.1°F (0.01°C)
DW-WIFI-TH-HA	Internal temperature/humidity	-4 to 140°F (-20 to 60°C), 0 to 100% RH	±0.4°F (±0.2°C) @ 41 to 140°F (5 to 60°C) ±2.5% RH @ 10 to 90% RH	0.5°F (0.5°C) 1.0% RH
DW-WIFI-TP-HA	Remote temperature probe	-40 to 257°F (-40 to 125°C)	±0.2°F (±0.1°C) @ 14 to 158°F (-10 to 70°C)	0.01°F (0.01°C)

\*Probe dependent



# Dwyer®

**Manufacturing Excellence Since 1931**

pressure • temperature • test & data • air quality

flow • level • process control • valves



## 2021

**[dwyer-inst.com](http://dwyer-inst.com)**

Phone: (219) 879-8000 | Fax: (219) 872-9057

